

DMC 200S - PLYWOOD

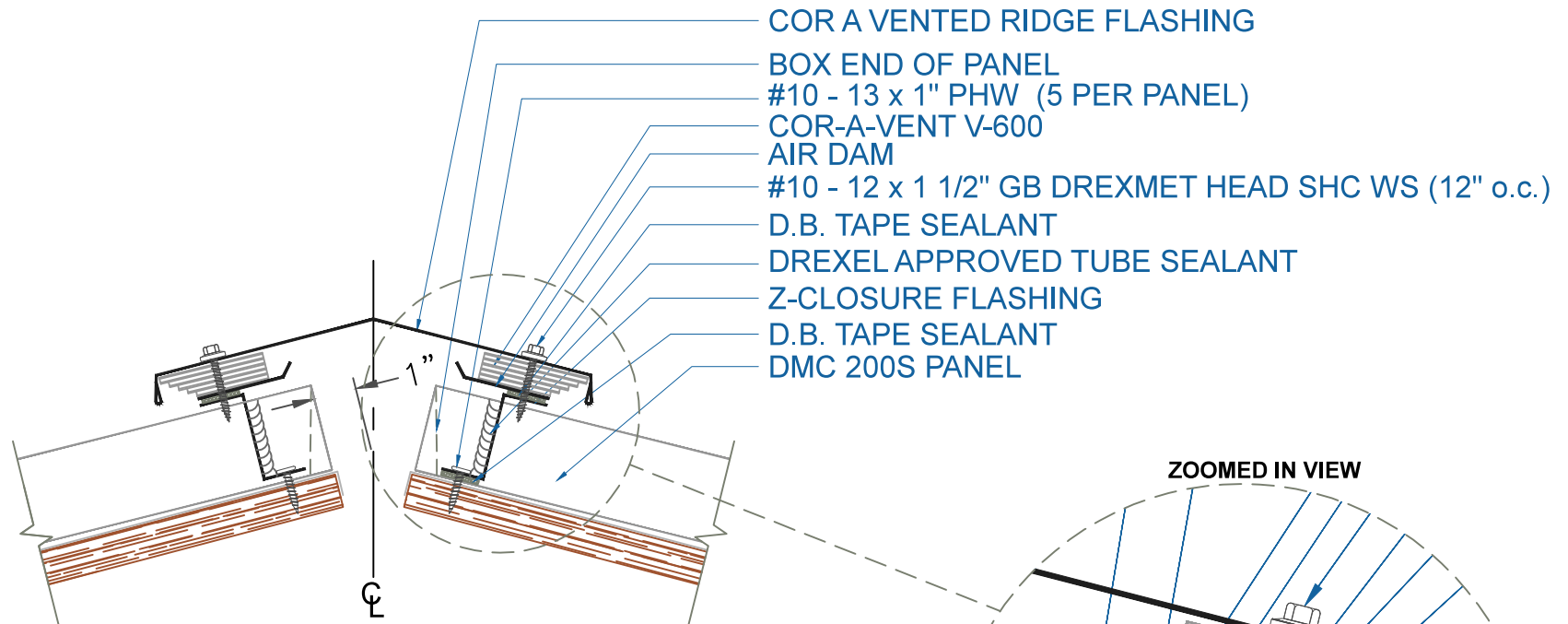

- COR A VENTED RIDGE FLASHING
- BOX END OF PANEL
- #10 - 13 x 1" PHW (5 PER PANEL)
- COR-A-VENT V-600
- AIR DAM
- #10 - 12 x 1 1/2" GB DREXMET HEAD SHC WS (12" o.c.)
- D.B. TAPE SEALANT
- DREXEL APPROVED TUBE SEALANT
- Z-CLOSURE FLASHING
- D.B. TAPE SEALANT
- DMC 200S PANEL

NOTE:
1.) NET FREE AREA = 20 SQ IN/FT

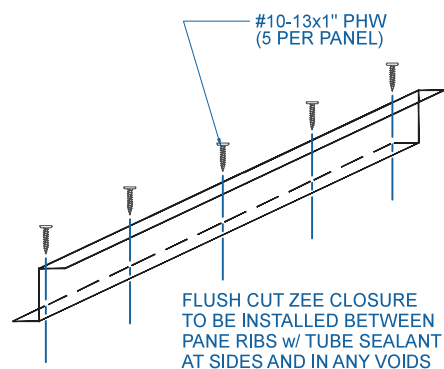

#10-13x1" PHW
(5 PER PANEL)

FLUSH CUT ZEE CLOSURE
TO BE INSTALLED BETWEEN
PANE RIBS w/ TUBE SEALANT
AT SIDES AND IN ANY VOIDS

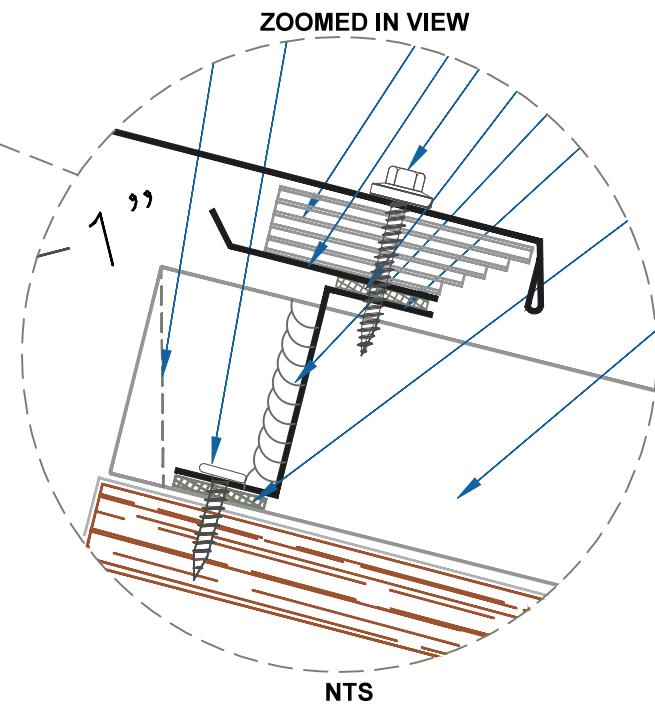

COR-A-VENTED RIDGE / HIP

SCALE: 3" = 1'-0"

EFFECTIVE DATE: 1-9-13
SUBJECT TO CHANGE WITHOUT NOTICE