

DMC 200S - OPEN FRAMING

DMC 200S PANEL
DREXEL APPROVED SEALANT
(FIELD OR MACHINE APPLIED SEALANT)
CLIP SEALANT
CLIP
(2) 1/4 - 14 x 1 1/2" DP3 SD/NW
FRAMING MEMBER

ZOOMED IN VIEW

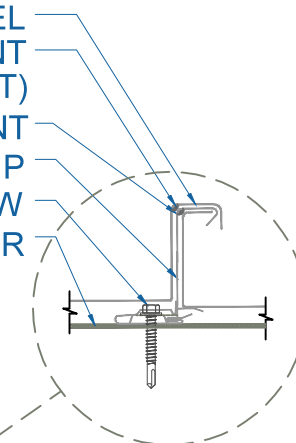

CROSS SECTION
BEFORE SEAMING

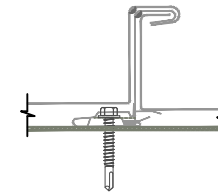

CROSS SECTION
90° SEAMING

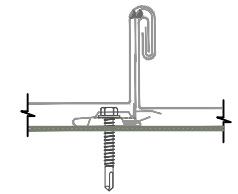

CROSS SECTION
180° SEAMING

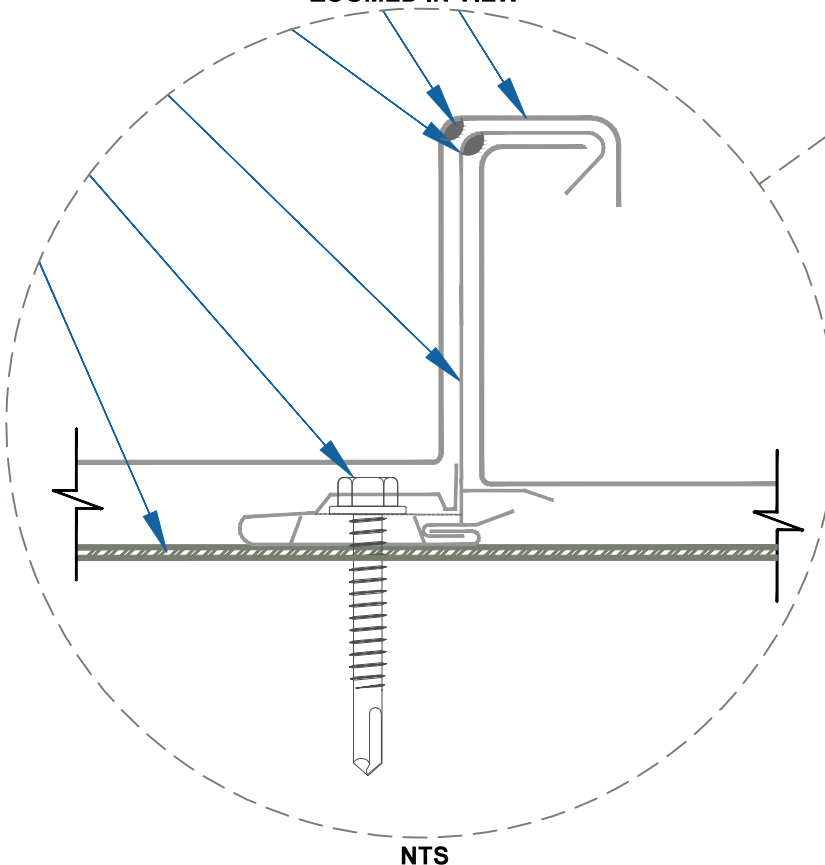

NTS

SEAMER TOOL RENTAL
SEAMER TOOLS, INC.
8265 HIGHWAY 178
OLIVE BRANCH, MS 38654
PH:(662)895-1222
FAX:(662)890-4775
RENT@SEAMERTOOLS.COM

EFFECTIVE DATE: 12-12-12
SUBJECT TO CHANGE WITHOUT NOTICE

INSTALLATION DETAIL

SCALE: 3" = 1'-0"

DrexelMetals
Roofing Systems + Custom Fabrication



DMC 200S - OPEN FRAMING

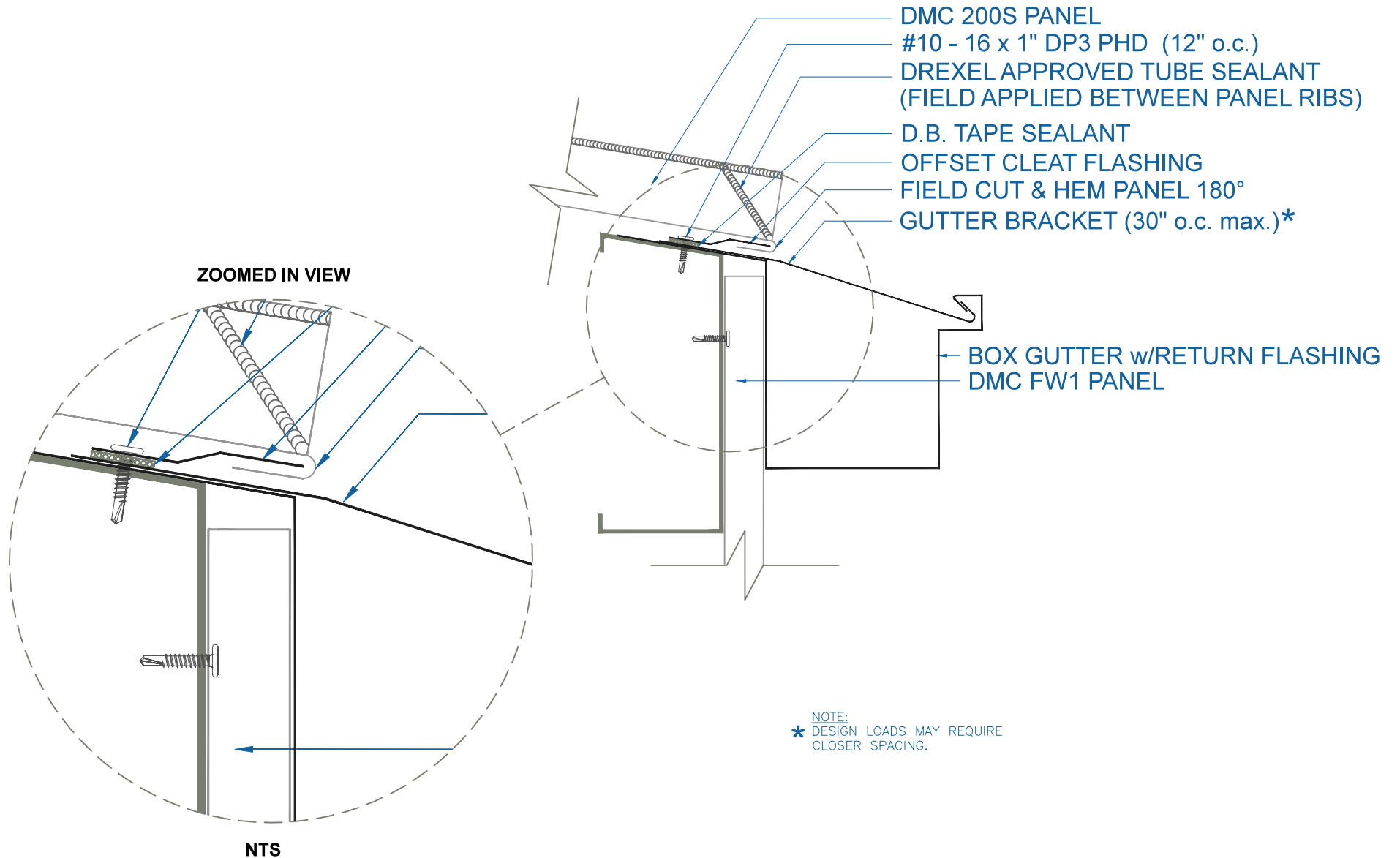

BOX GUTTER - w/RETURN w/FLUSH PANEL

EFFECTIVE DATE: 12-12-12
SUBJECT TO CHANGE WITHOUT NOTICE

SCALE: 3" = 1'-0"

DMC 200S - OPEN FRAMING

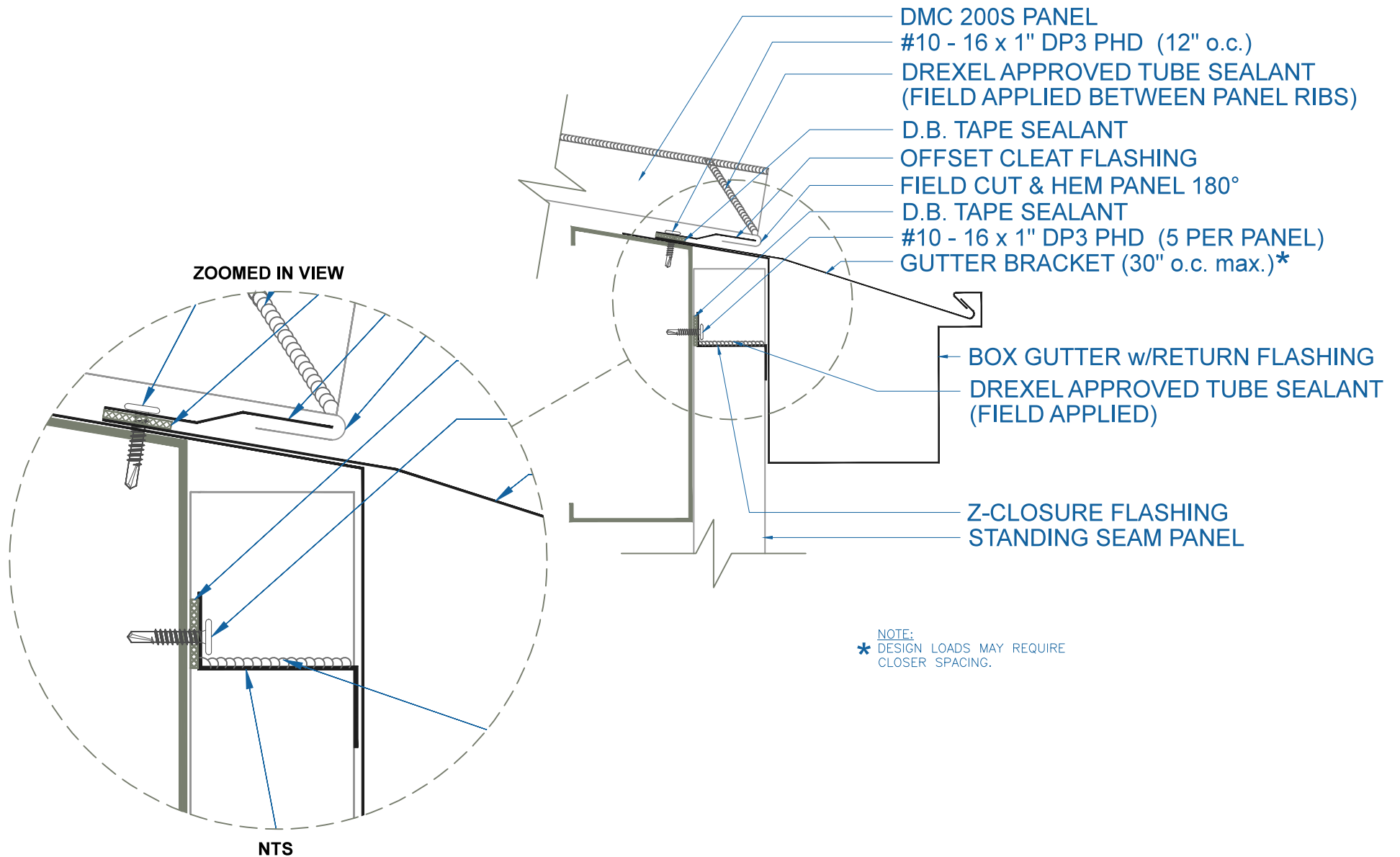

BOX GUTTER w/RETURN w/STANDING SEAM PANEL

SCALE: 3" = 1'-0"

EFFECTIVE DATE: 12-12-12
SUBJECT TO CHANGE WITHOUT NOTICE

DrexelMetals
Roofing Systems + Custom Fabrication



DMC 200S - OPEN FRAMING

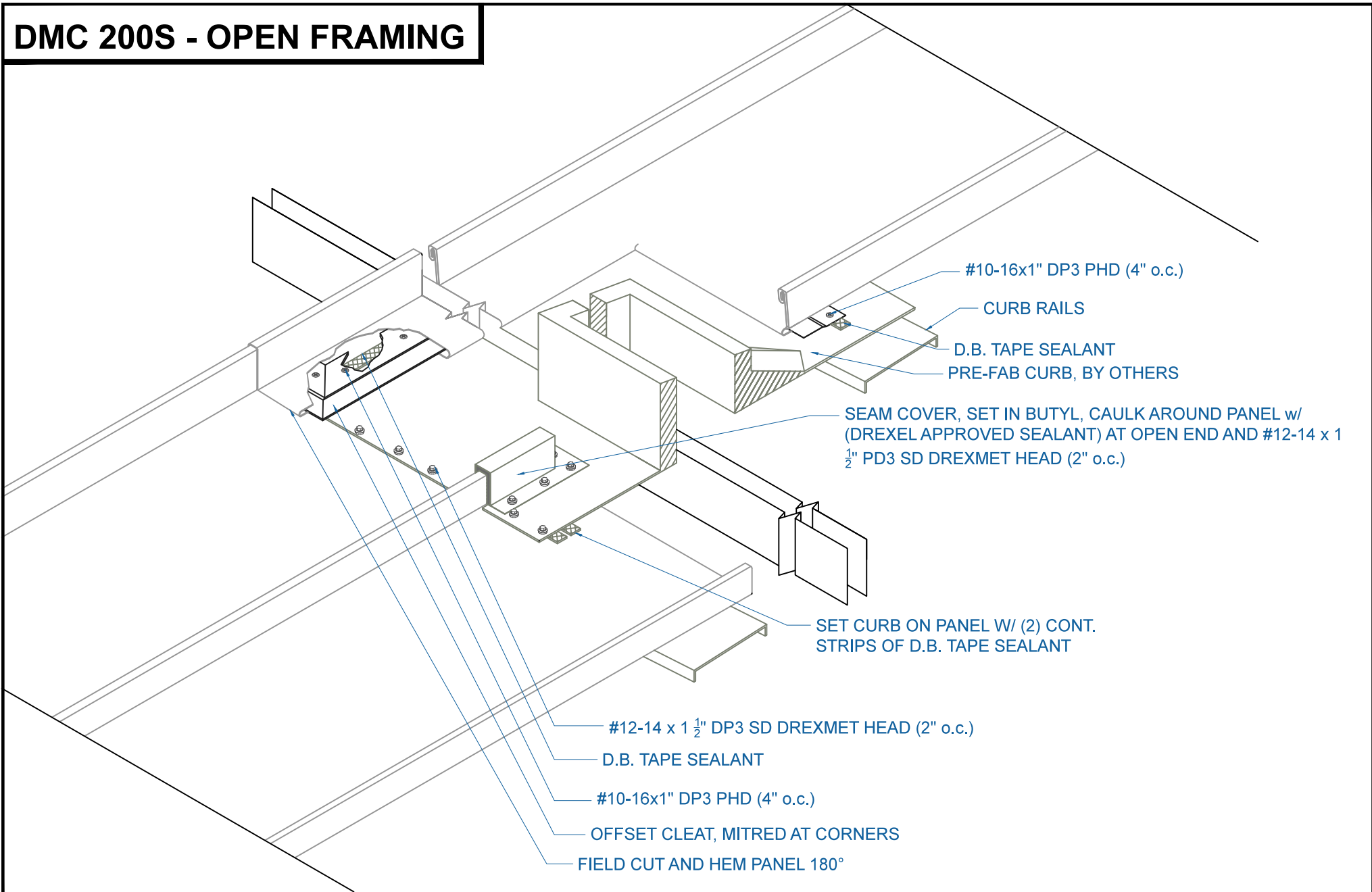

EFFECTIVE DATE: 12-12-12
SUBJECT TO CHANGE WITHOUT NOTICE

CURB DETAIL

SCALE: NTS



DMC 200S - OPEN FRAMING

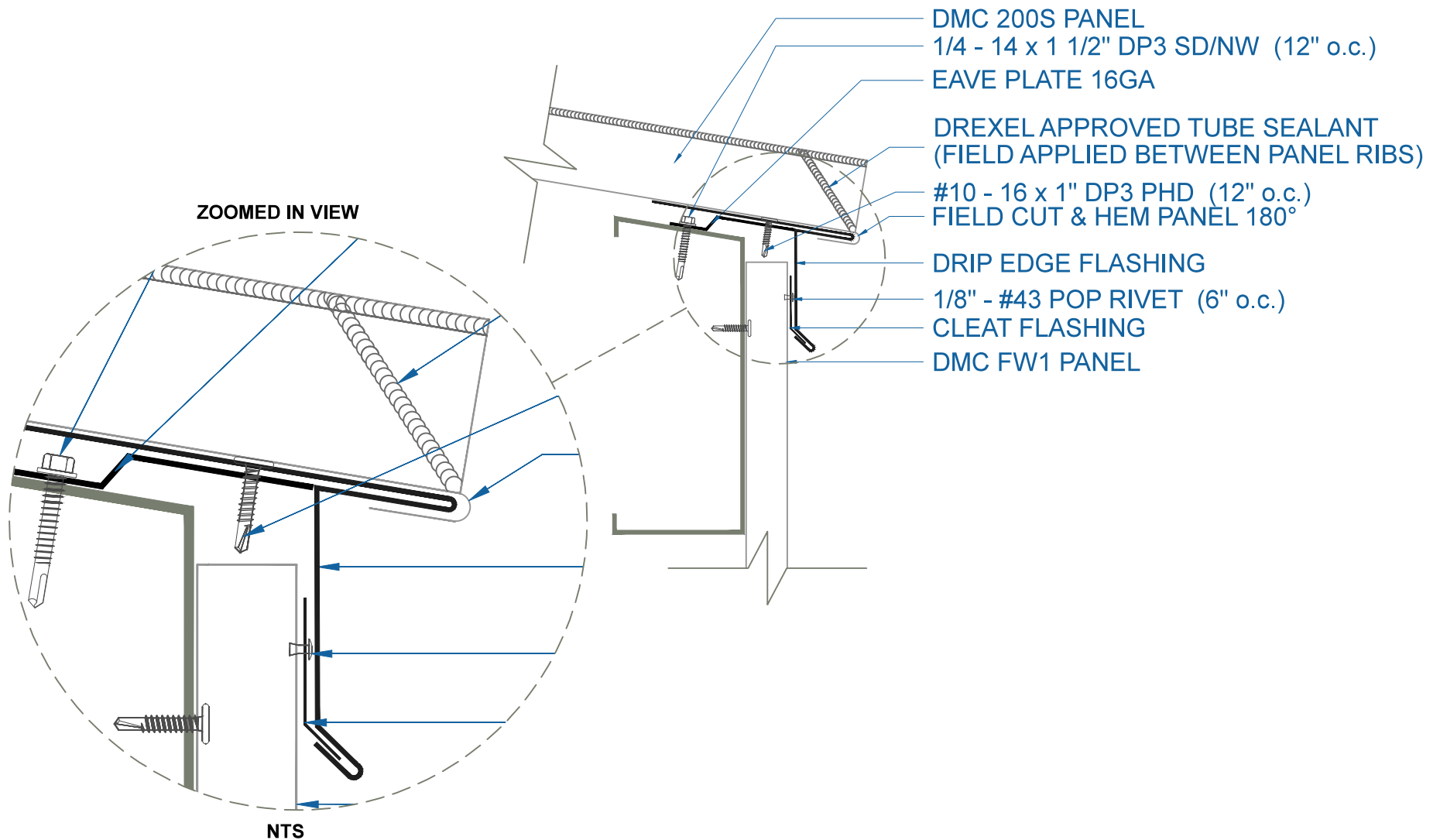

DRIP EDGE w/FLUSH PANEL

SCALE: 3" = 1'-0"

EFFECTIVE DATE: 12-12-12
SUBJECT TO CHANGE WITHOUT NOTICE

DMC 200S - OPEN FRAMING

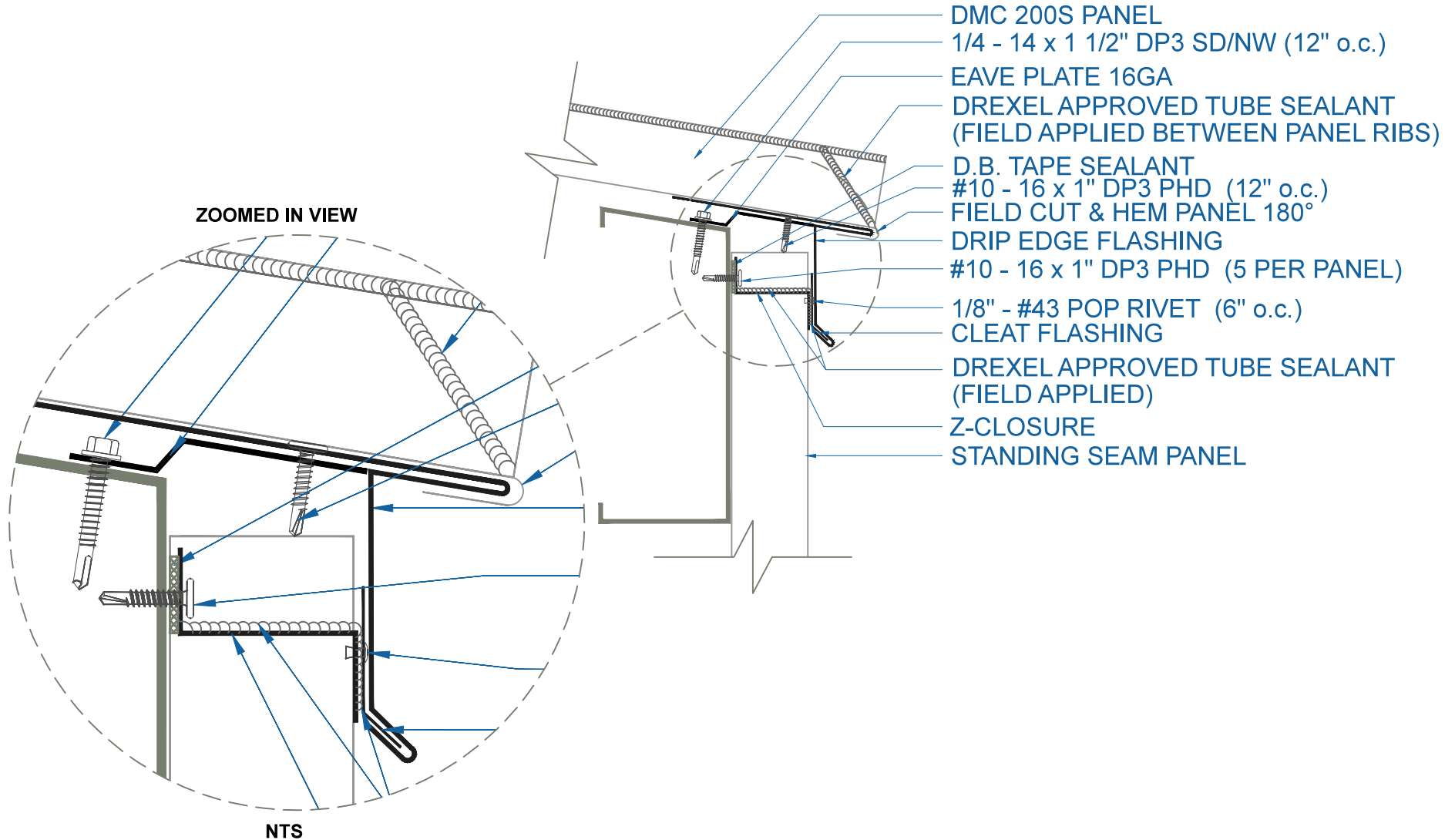

DRIP EDGE w/STANDING SEAM PANEL

EFFECTIVE DATE: 12-12-12
SUBJECT TO CHANGE WITHOUT NOTICE

SCALE: 3" = 1'-0"

DMC 200S - OPEN FRAMING

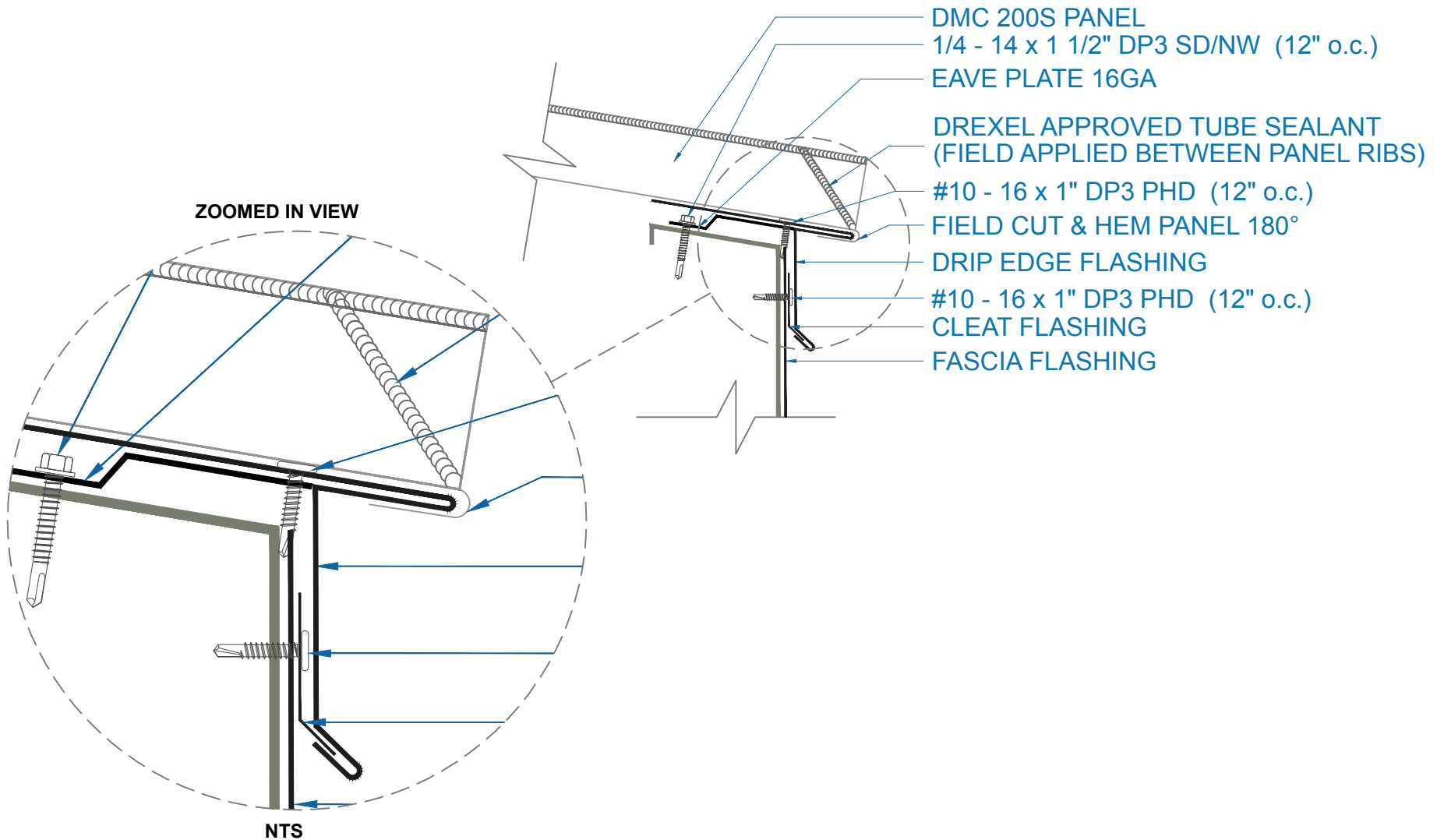

DRIP EDGE

SCALE: 3" = 1'-0"

EFFECTIVE DATE: 11-18-16
SUBJECT TO CHANGE WITHOUT NOTICE

DMC 200S - OPEN FRAMING

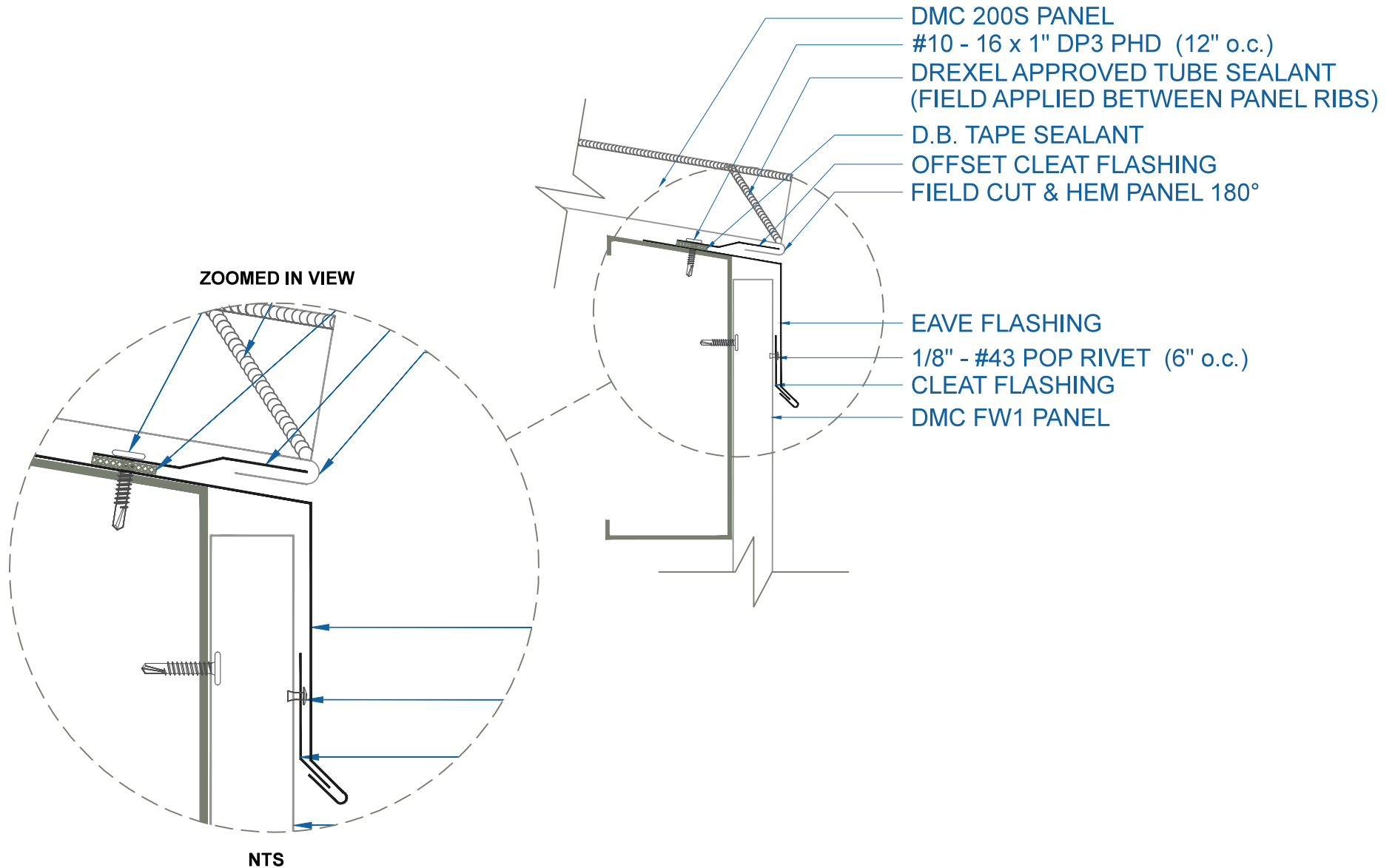

EAVE w/FLUSH PANEL

SCALE: 3" = 1'-0"

EFFECTIVE DATE: 12-12-12
SUBJECT TO CHANGE WITHOUT NOTICE



DMC 200S - OPEN FRAMING

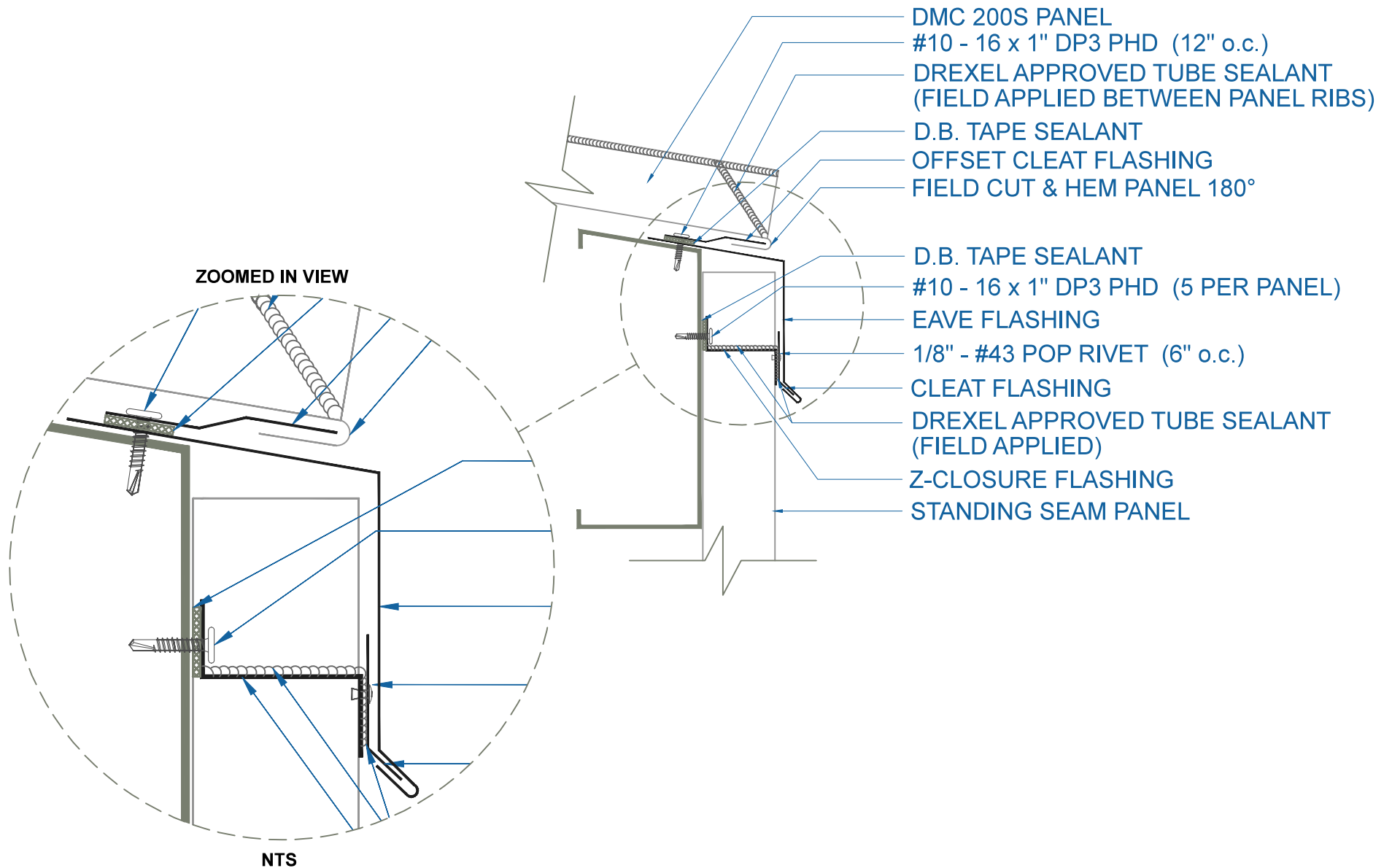

EAVE w/STANDING SEAM PANEL

SCALE: 3" = 1'-0"

EFFECTIVE DATE: 12-12-12
SUBJECT TO CHANGE WITHOUT NOTICE



DMC 200S - OPEN FRAMING

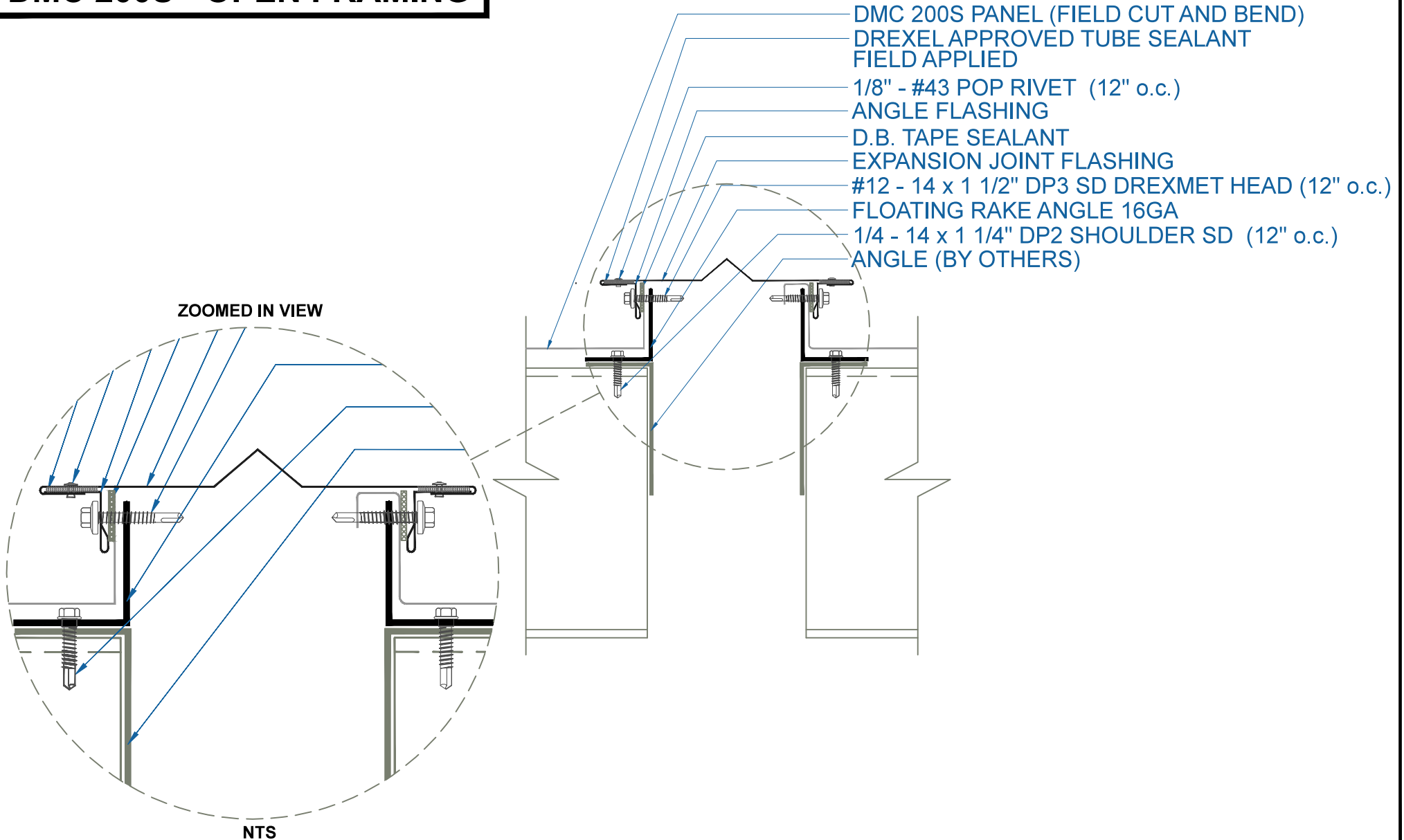

EXPANSION JOINT

SCALE: 3" = 1'-0"

EFFECTIVE DATE: 12-12-12
SUBJECT TO CHANGE WITHOUT NOTICE

DMC 200S - OPEN FRAMING

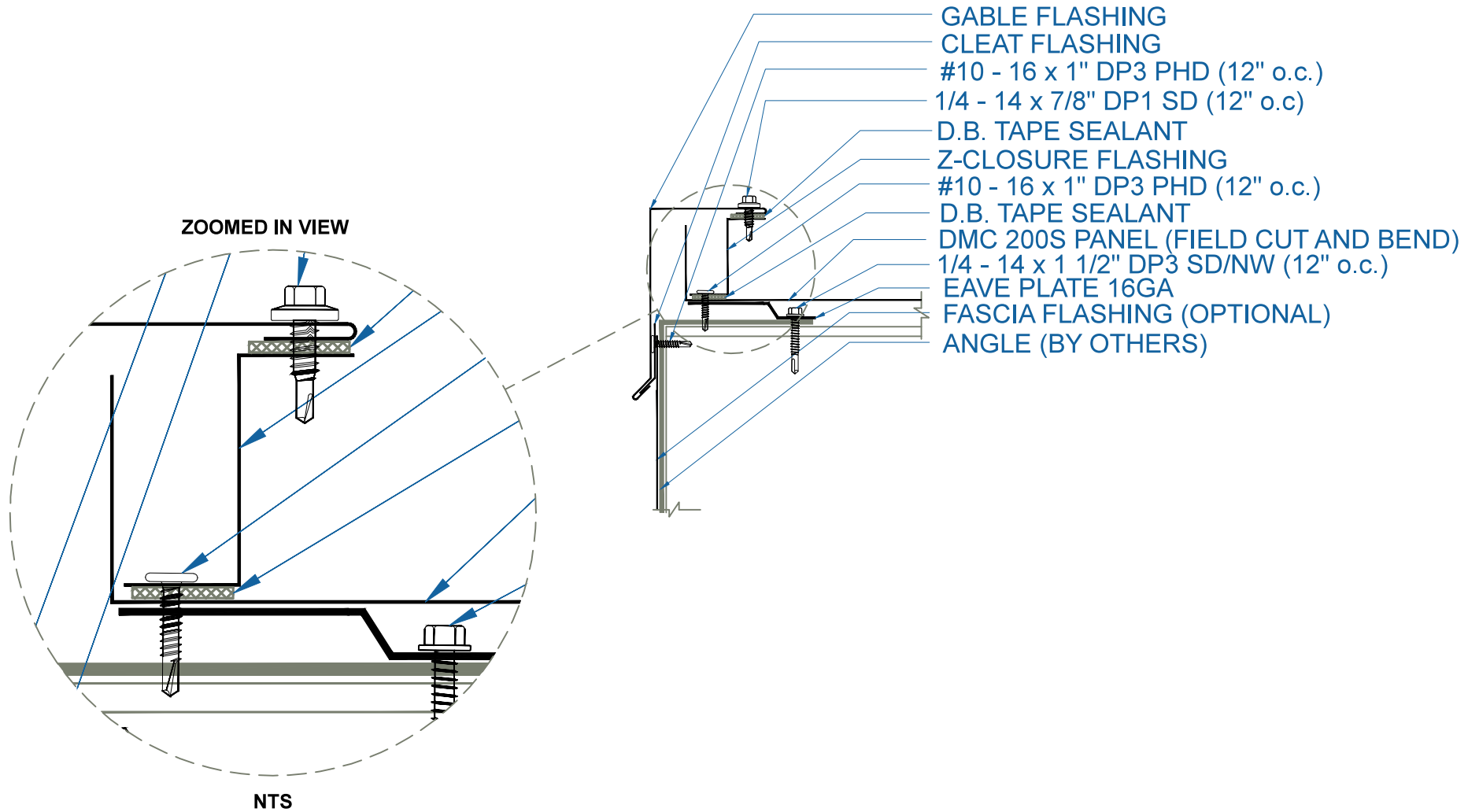

EFFECTIVE DATE: 01-16-14
 SUBJECT TO CHANGE WITHOUT NOTICE

GABLE
 SCALE: 3" = 1'-0"

DMC 200S - OPEN FRAMING

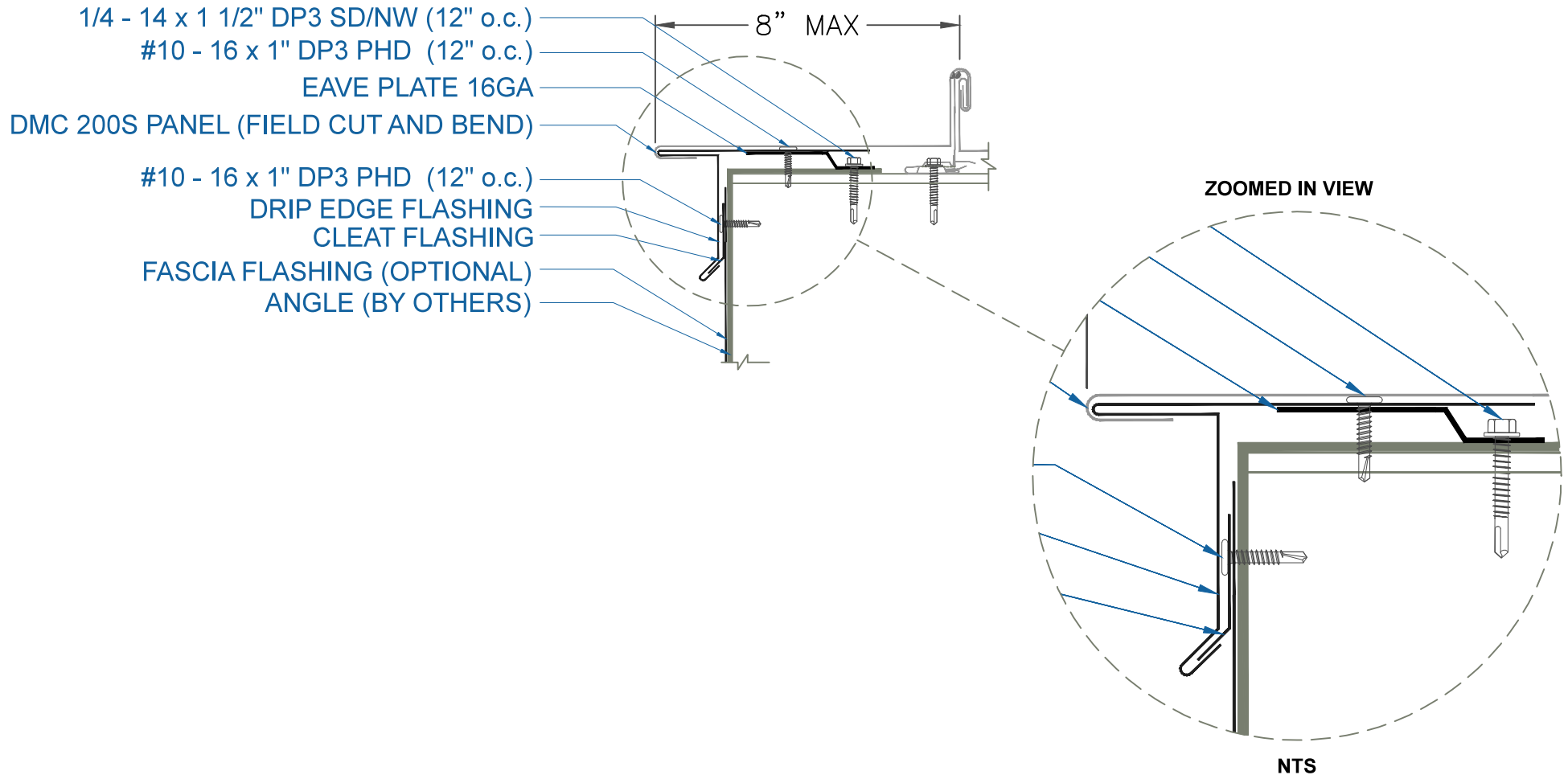

GABLE ALTERNATE / CURVED

SCALE: 3" = 1'-0"

DMC 200S - OPEN FRAMING

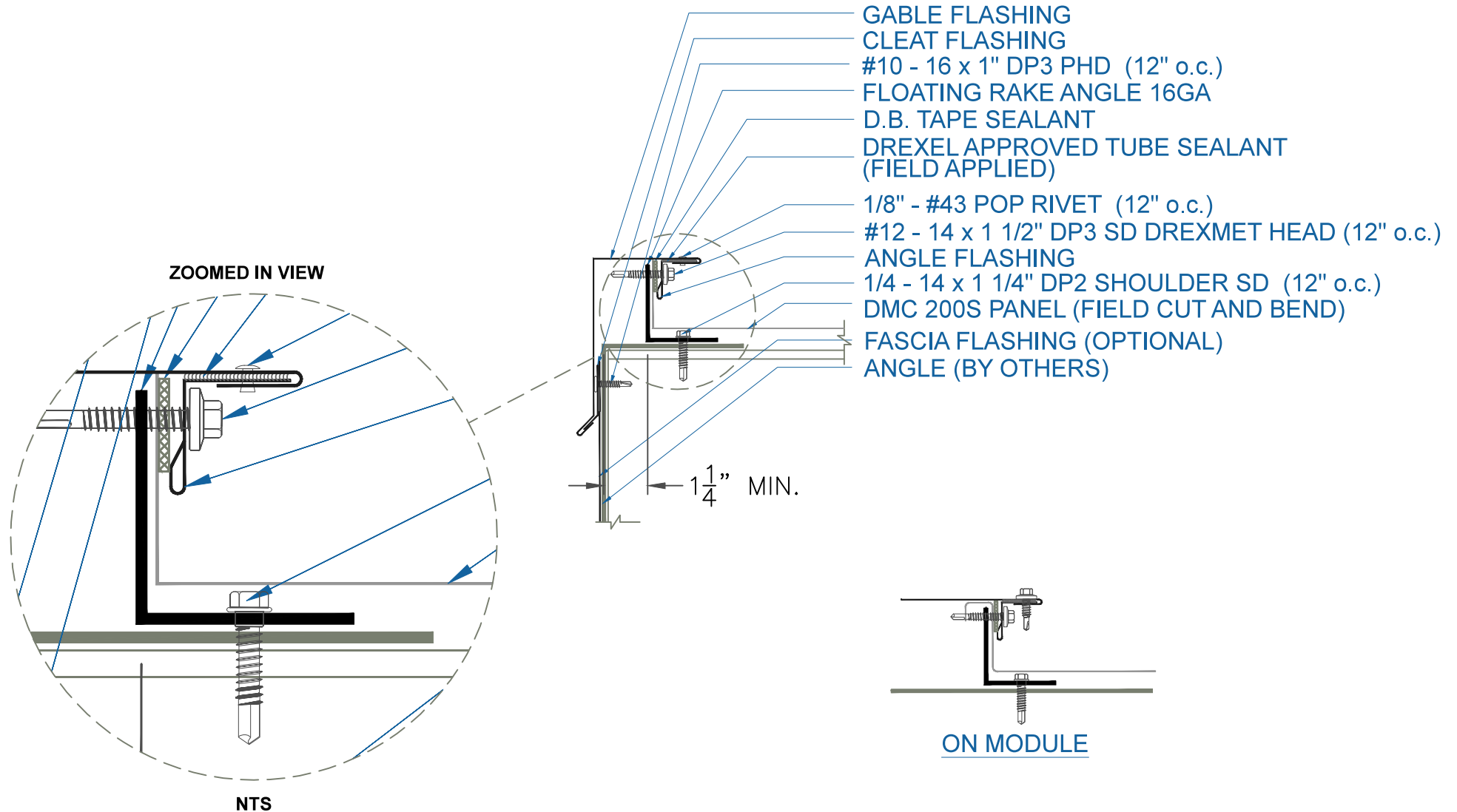

EFFECTIVE DATE: 12-12-12
 SUBJECT TO CHANGE WITHOUT NOTICE

GABLE
 SCALE: 3" = 1'-0"

DrexelMetals
 Roofing Systems + Custom Fabrication



DMC 200S - OPEN FRAMING

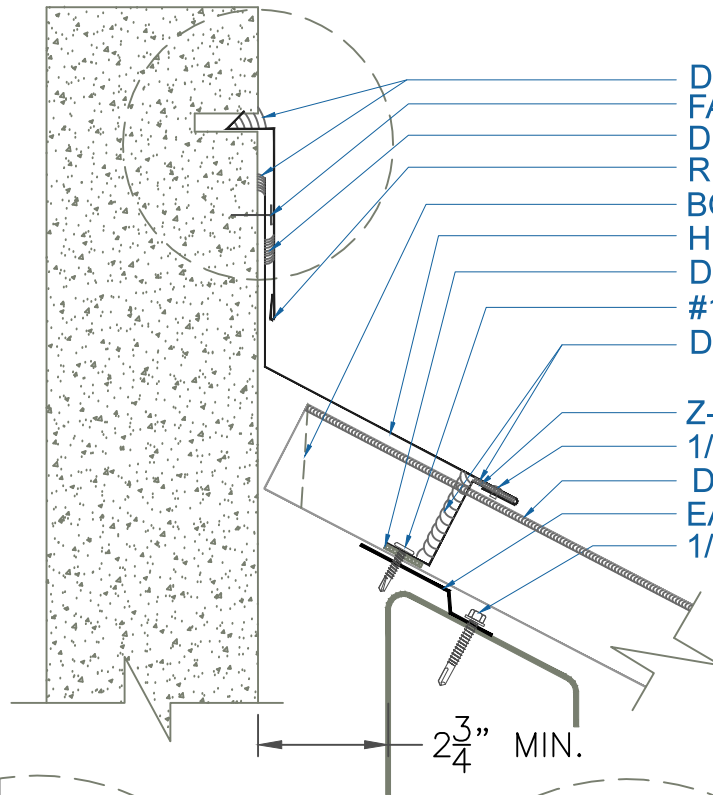

- DREXEL APPROVED TUBE SEALANT
- FASTENERS (BY OTHERS)
- DREXEL APPROVED TUBE SEALANT
- REGLET FLASHING
- BOX END OF PANEL
- HEADWALL FLASHING
- D.B. TAPE SEALANT
- #10 - 16 x 1" DP3 PHD (5 PER PANEL)
- DREXEL APPROVED TUBE SEALANT (FIELD APPLIED)

- Z-CLOSURE FLASHING
- 1/8" - #43 POP RIVET (18" o.c.)
- DMC 200S PANEL (FIELD CUT AND BEND)
- EAVE PLATE 16GA
- 1/4 - 14 x 1 1/2" DP3 SD/NW (12" o.c.)

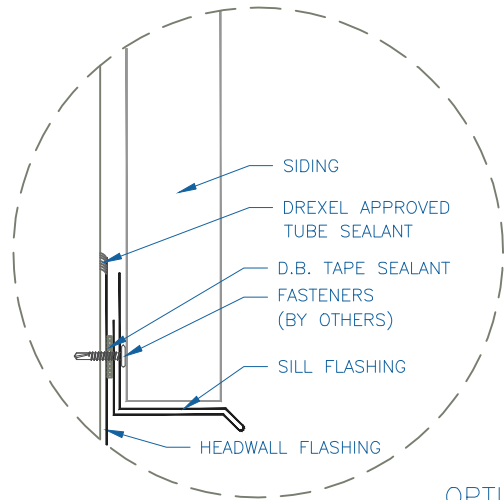

OPTION 1

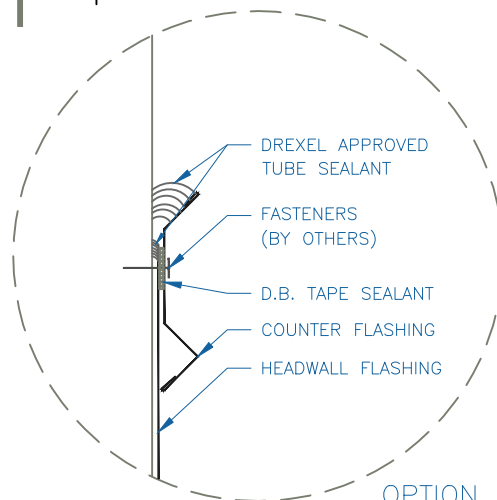

OPTION 2

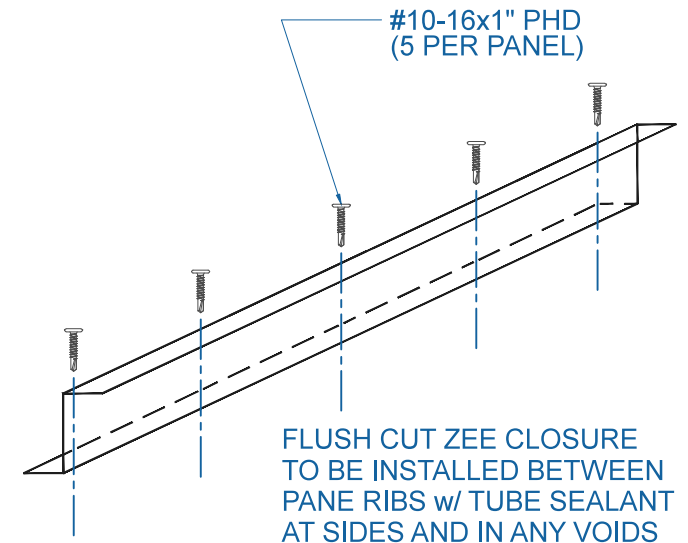

#10-16x1" PHD
(5 PER PANEL)

FLUSH CUT ZEE CLOSURE
TO BE INSTALLED BETWEEN
PANE RIBS w/ TUBE SEALANT
AT SIDES AND IN ANY VOIDS

EFFECTIVE DATE: 12-12-12
SUBJECT TO CHANGE WITHOUT NOTICE

HEADWALL

SCALE: 3" = 1'-0"

DMC 200S - OPEN FRAMING

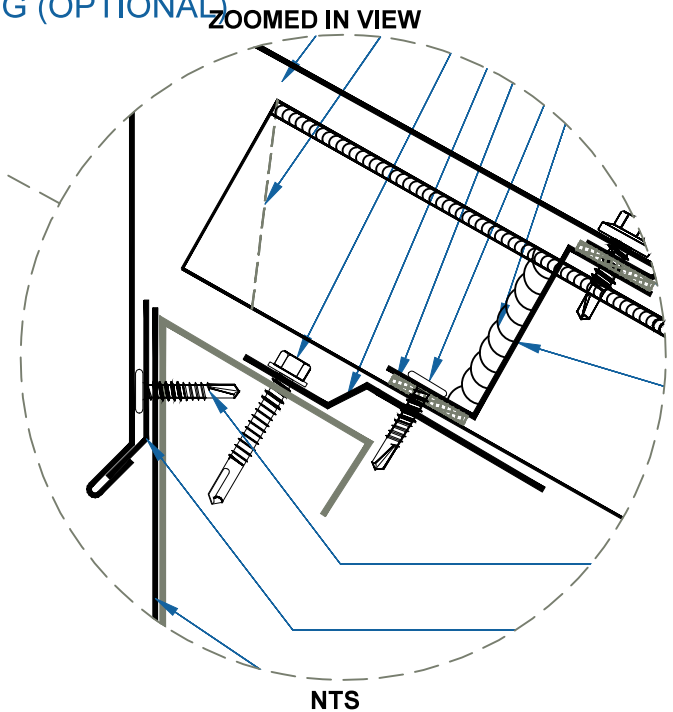
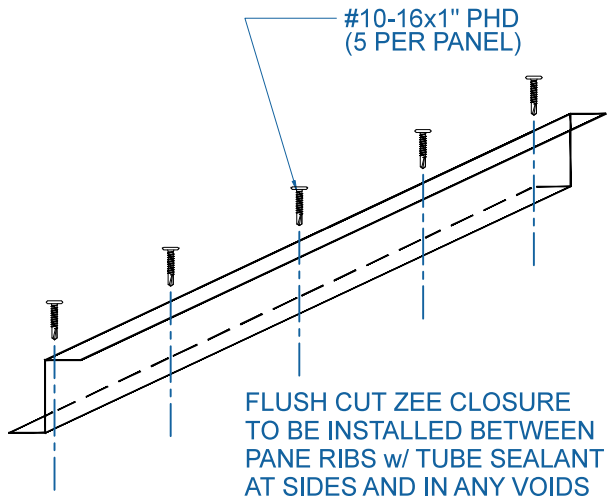
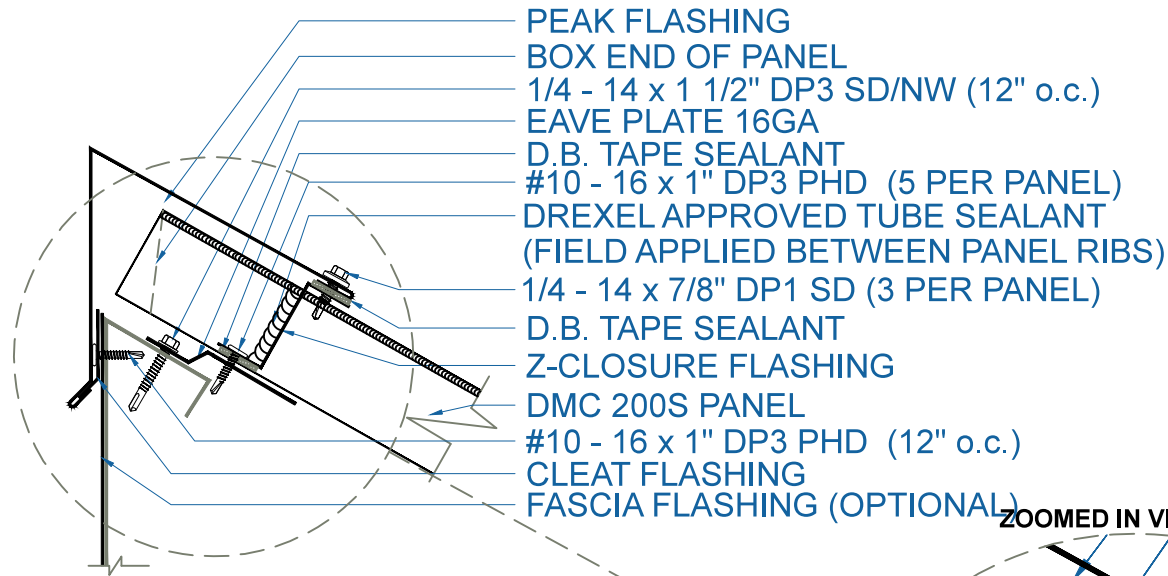

EFFECTIVE DATE: 01-16-14
SUBJECT TO CHANGE WITHOUT NOTICE

PEAK
SCALE: 3" = 1'-0"

DrexelMetals
Roofing Systems + Custom Fabrication



DMC 200S - OPEN FRAMING

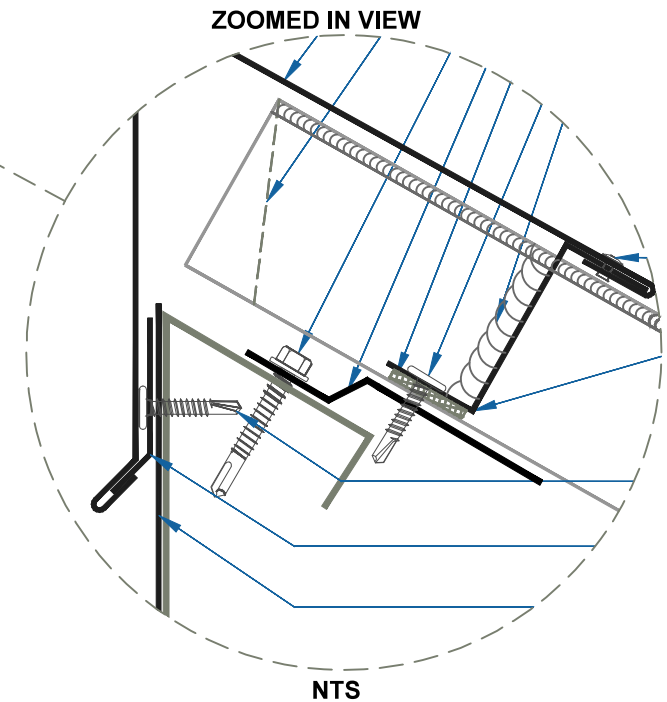
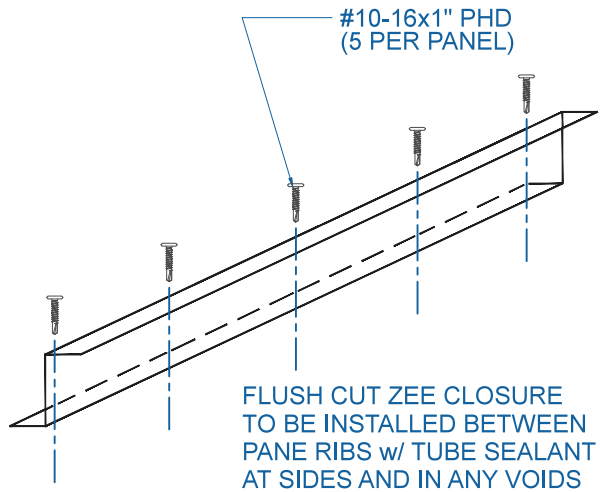
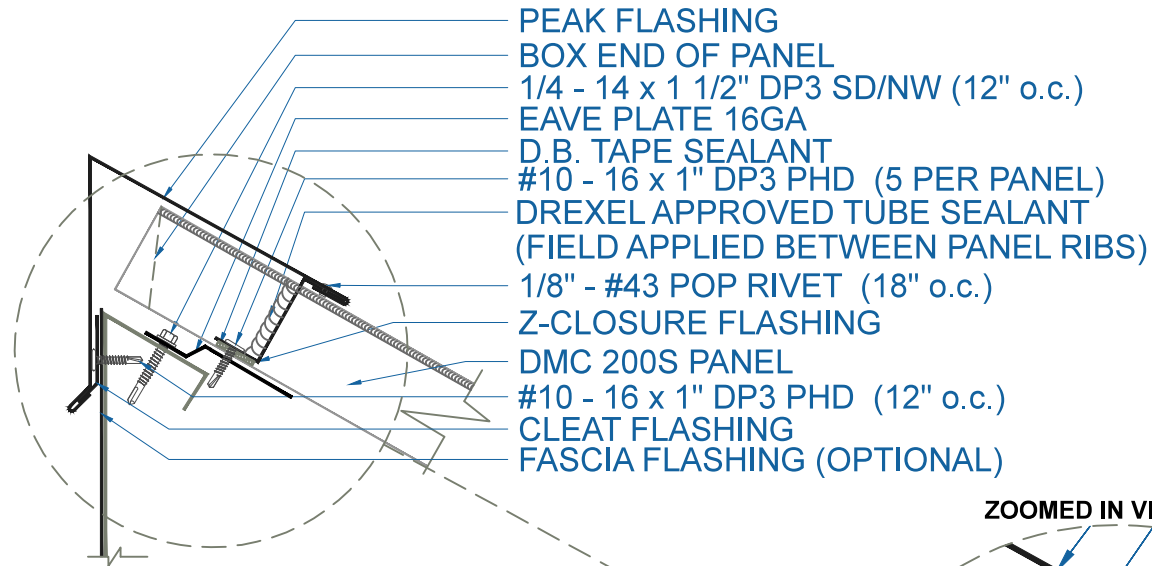

EFFECTIVE DATE: 12-12-12
 SUBJECT TO CHANGE WITHOUT NOTICE

PEAK
 SCALE: 3" = 1'-0"

DrexelMetals
 Roofing Systems + Custom Fabrication



DMC 200S - OPEN FRAMING

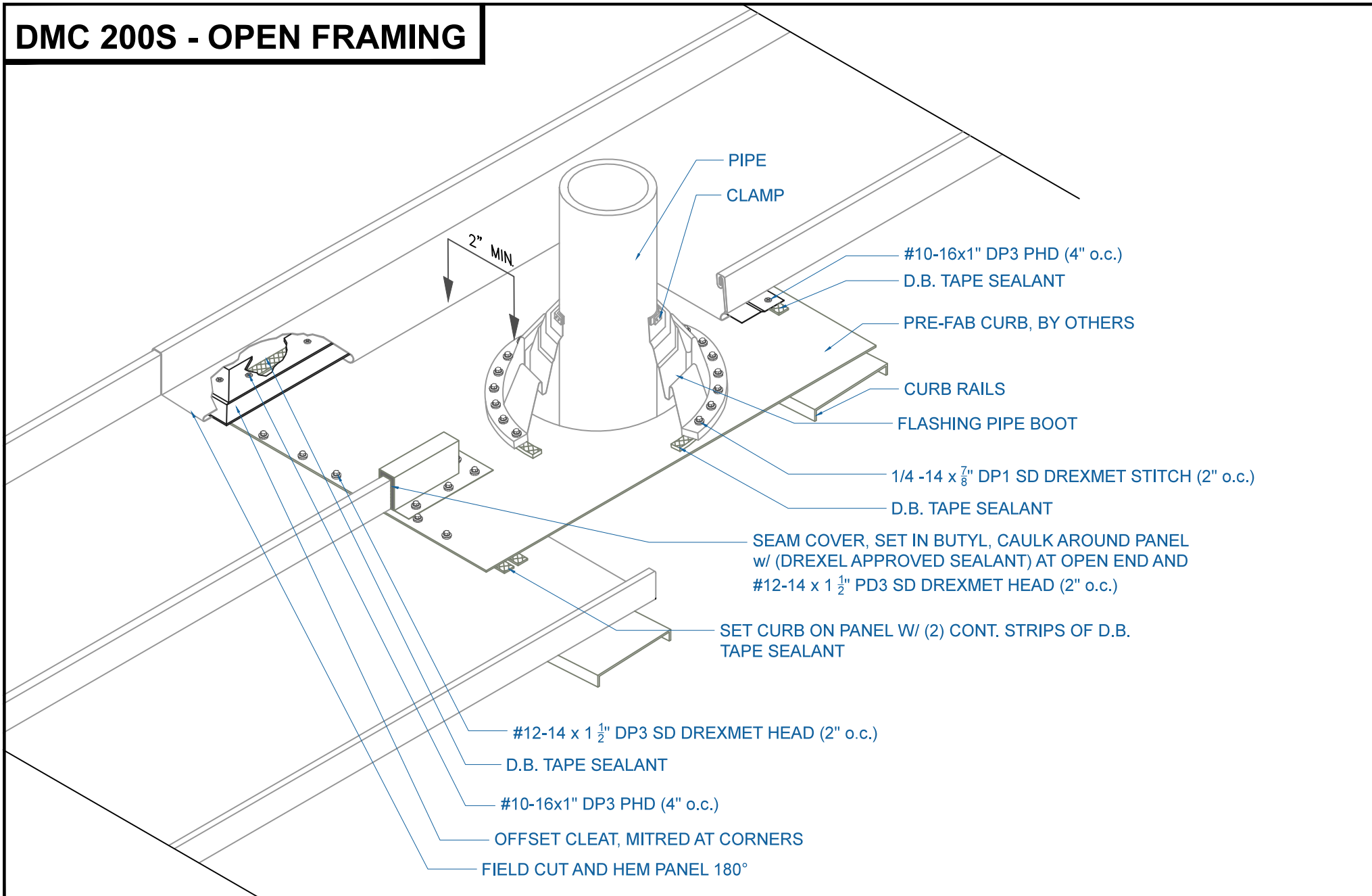

PIPE FLASHING DETAIL

SCALE: NTS

DMC 200S - OPEN FRAMING

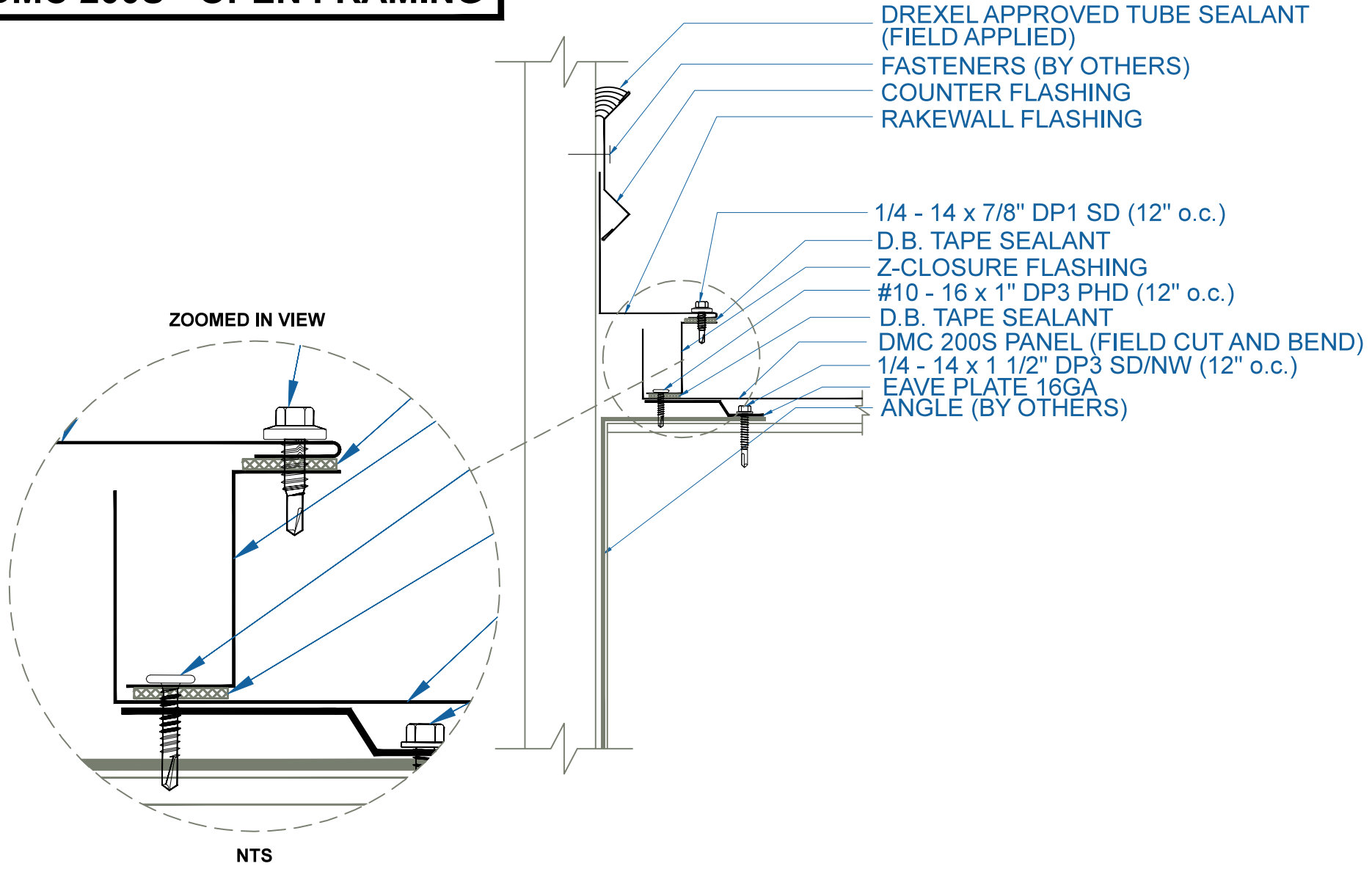

EFFECTIVE DATE: 01-16-14
 SUBJECT TO CHANGE WITHOUT NOTICE

RAKEWALL
 SCALE: 3" = 1'-0"

DMC 200S - OPEN FRAMING

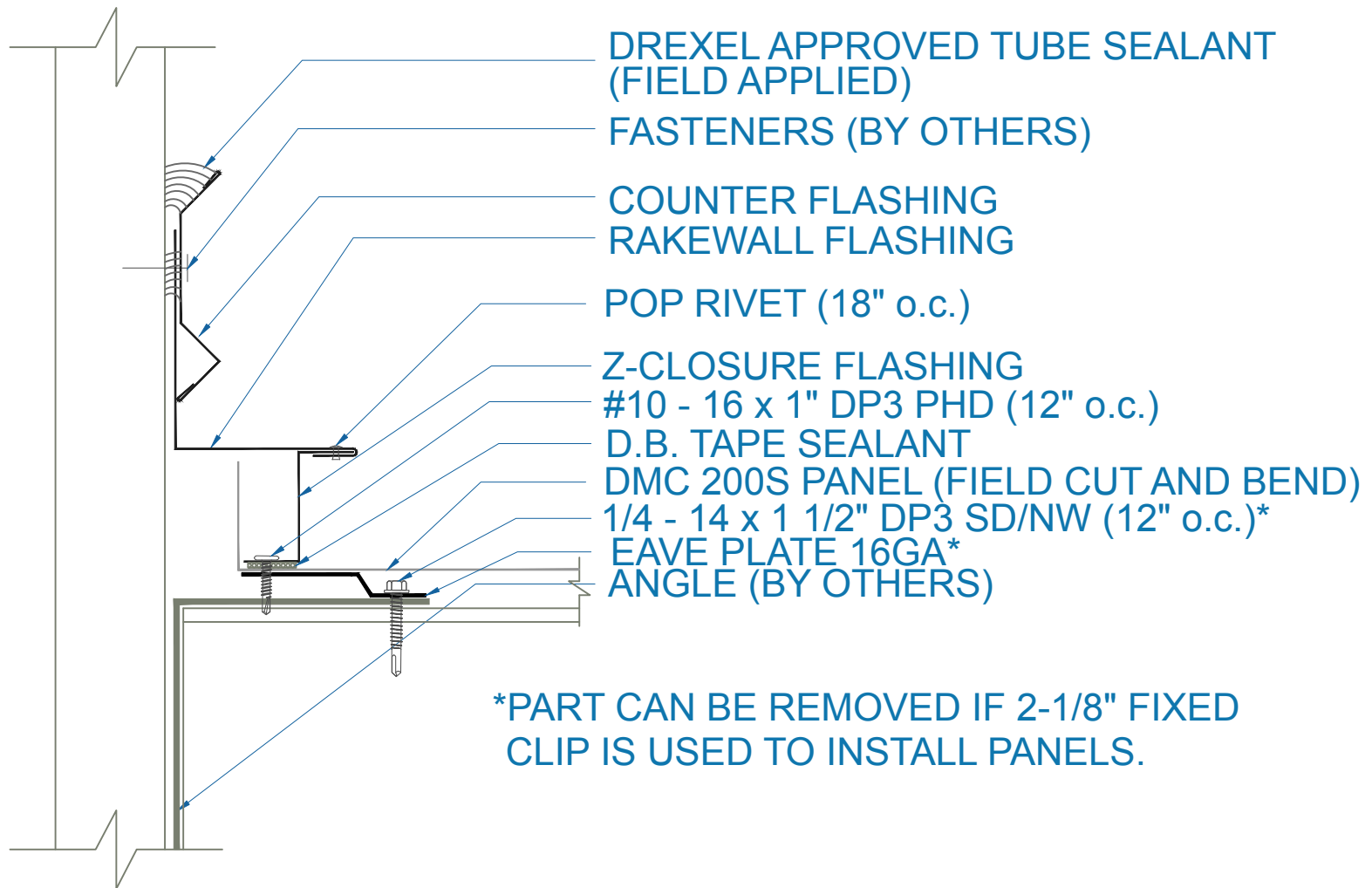

EFFECTIVE DATE: 03-1-17
SUBJECT TO CHANGE WITHOUT NOTICE

RAKEWALL

SCALE: 4" = 1'-0"

DrexelMetals
Roofing Systems + Custom Fabrication



DMC 200S - OPEN FRAMING

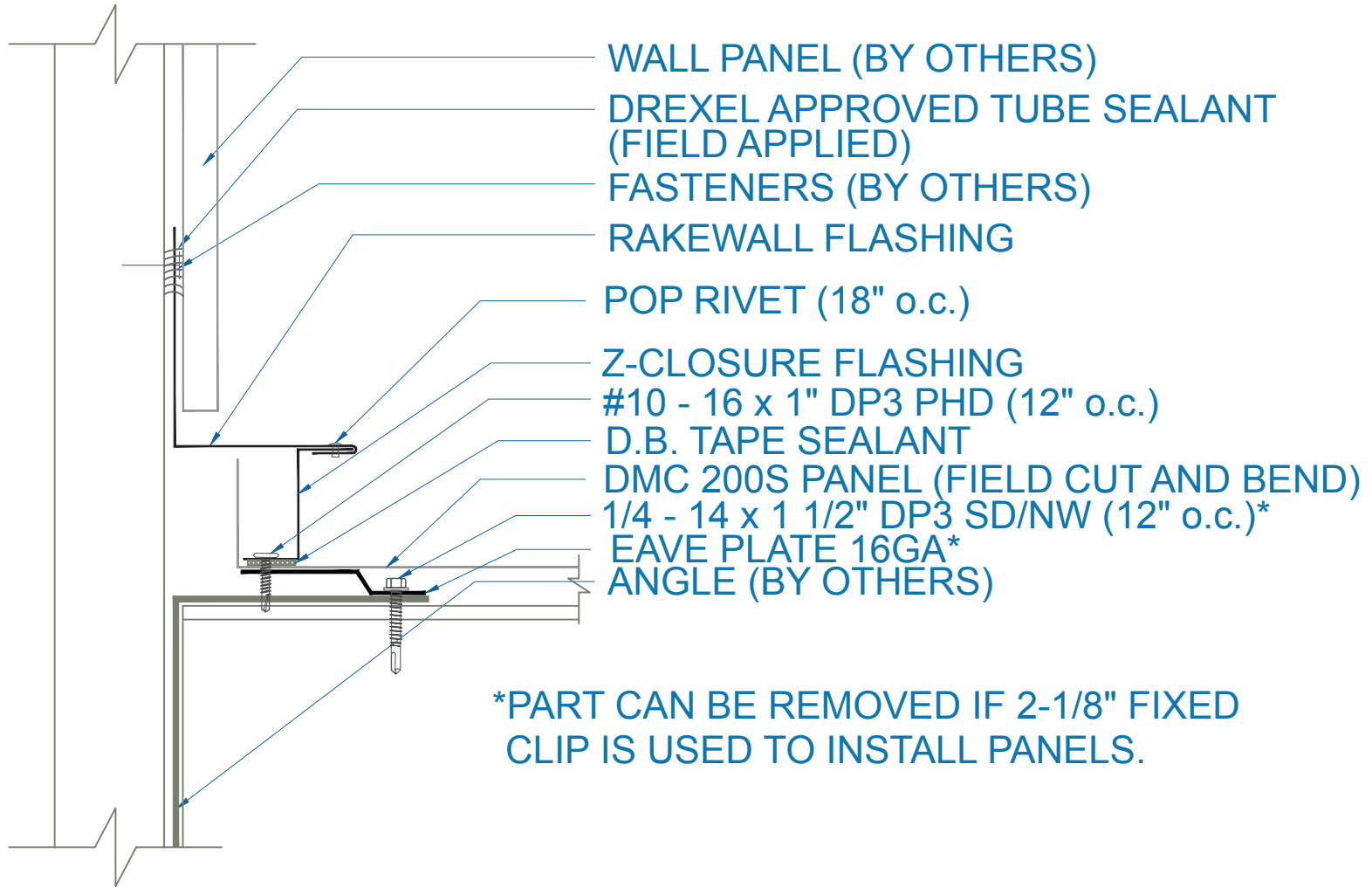

EFFECTIVE DATE: 03-1-17
SUBJECT TO CHANGE WITHOUT NOTICE

RAKEWALL

SCALE: 4" = 1'-0"

Drexel Metals
Roofing Systems + Custom Fabrication



DMC 200S - OPEN FRAMING

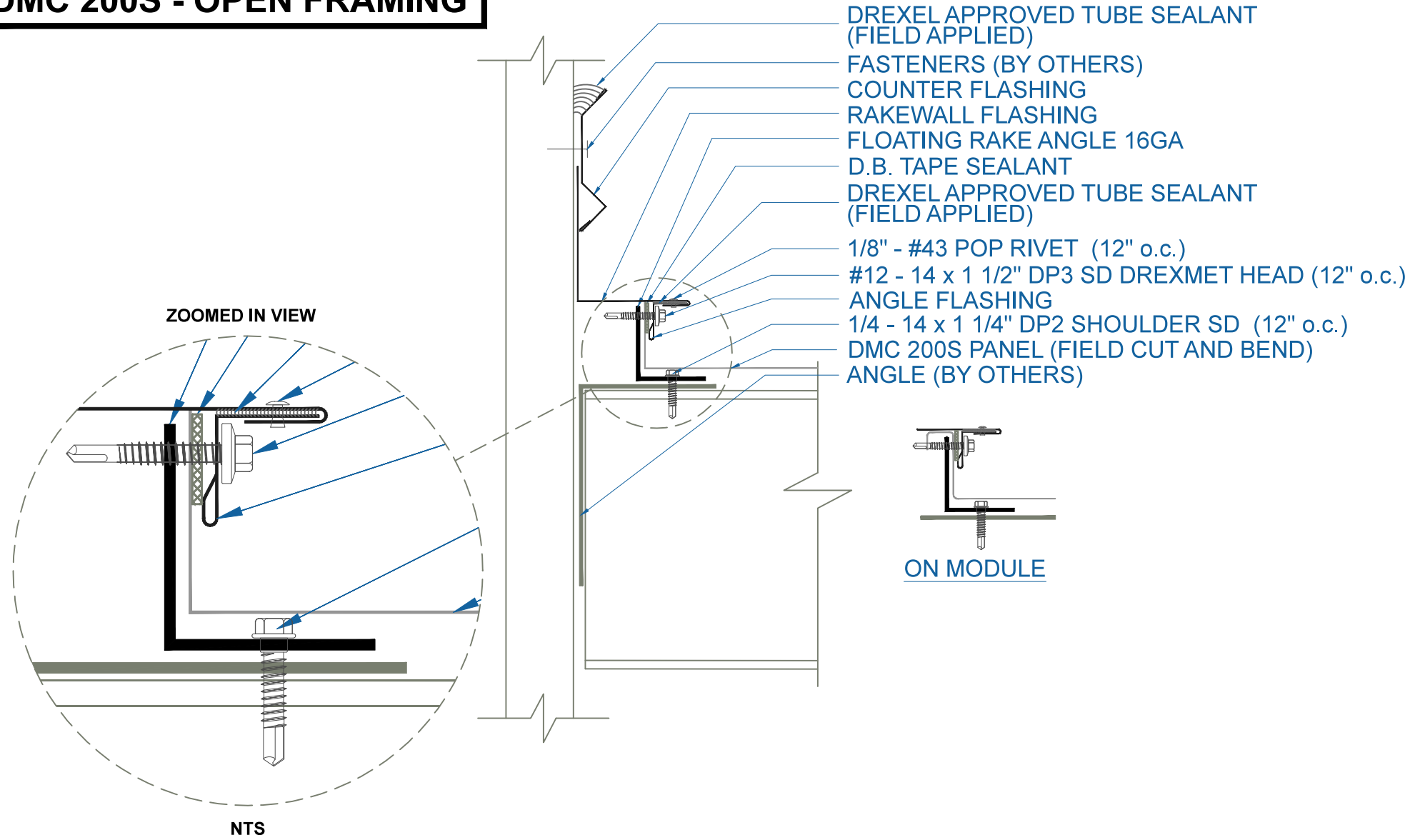

EFFECTIVE DATE: 12-12-12
 SUBJECT TO CHANGE WITHOUT NOTICE

RAKEWALL
 SCALE: 3" = 1'-0"

DMC 200S - OPEN FRAMING

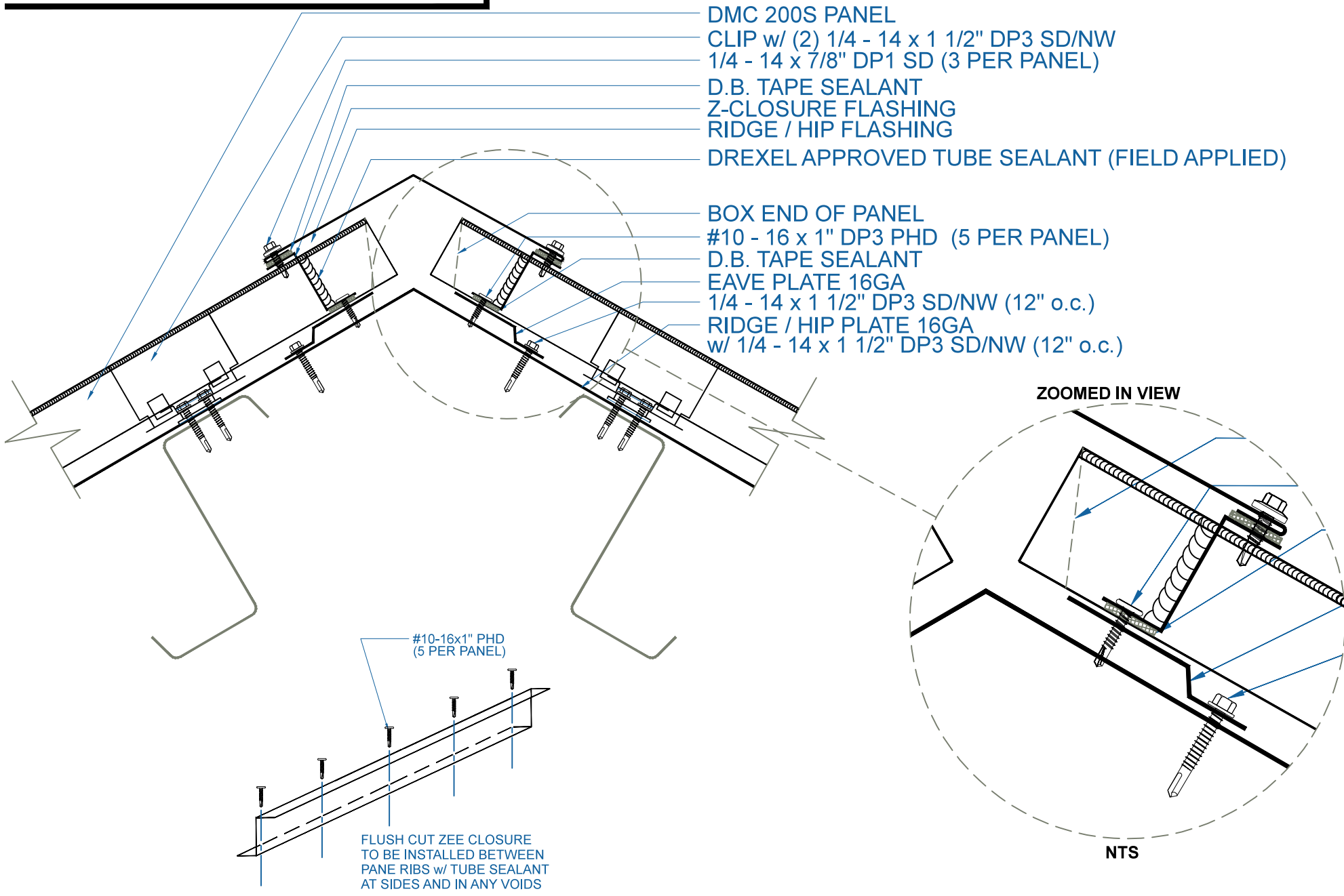

EFFECTIVE DATE: 01-16-14
 SUBJECT TO CHANGE WITHOUT NOTICE

RIDGE / HIP
 SCALE: 3" = 1'-0"

DMC 200S - OPEN FRAMING

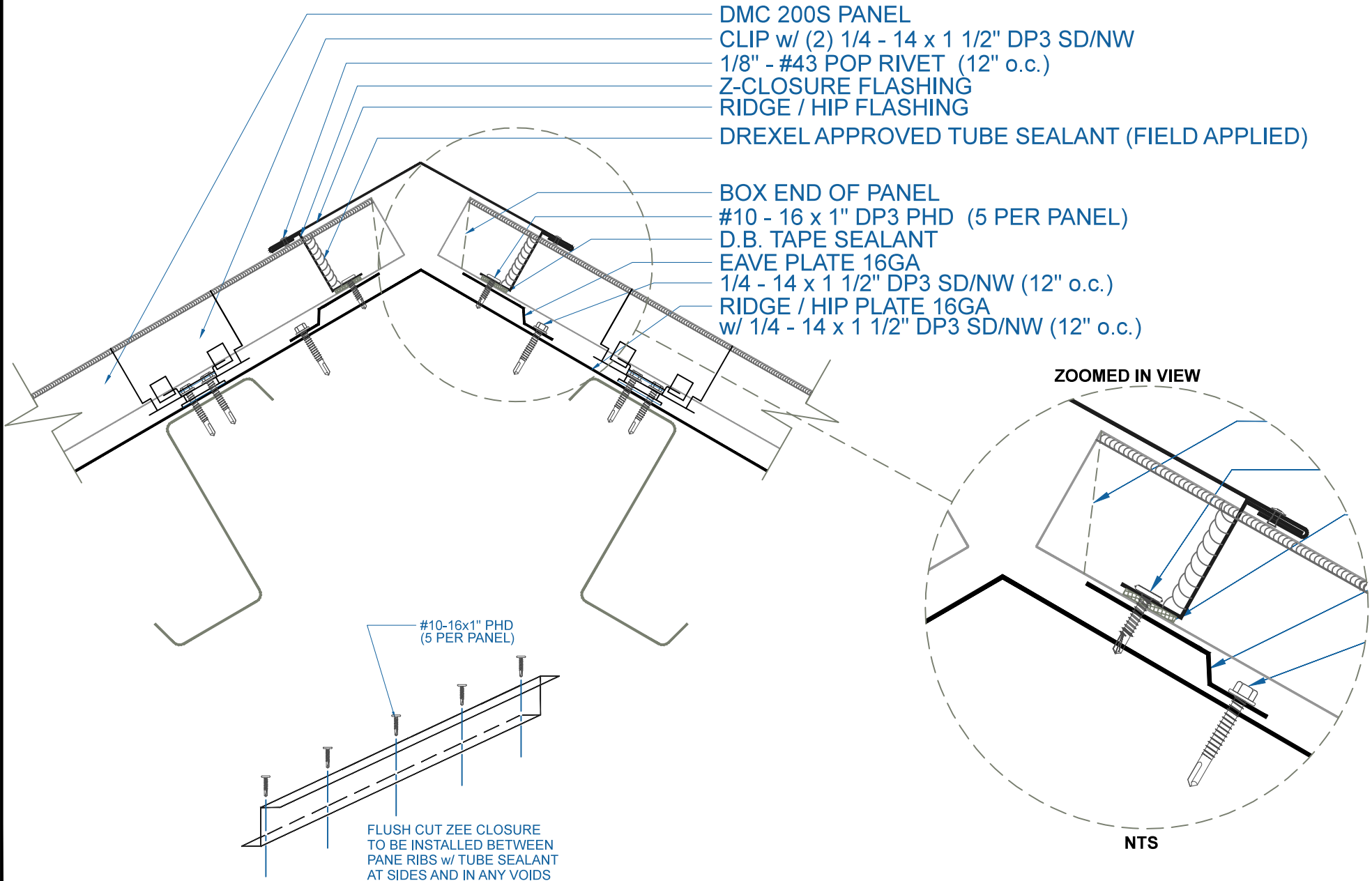

EFFECTIVE DATE: 12-12-12
 SUBJECT TO CHANGE WITHOUT NOTICE

RIDGE / HIP

SCALE: 3" = 1'-0"

DrexelMetals
 Roofing Systems + Custom Fabrication



DMC 200S - OPEN FRAMING

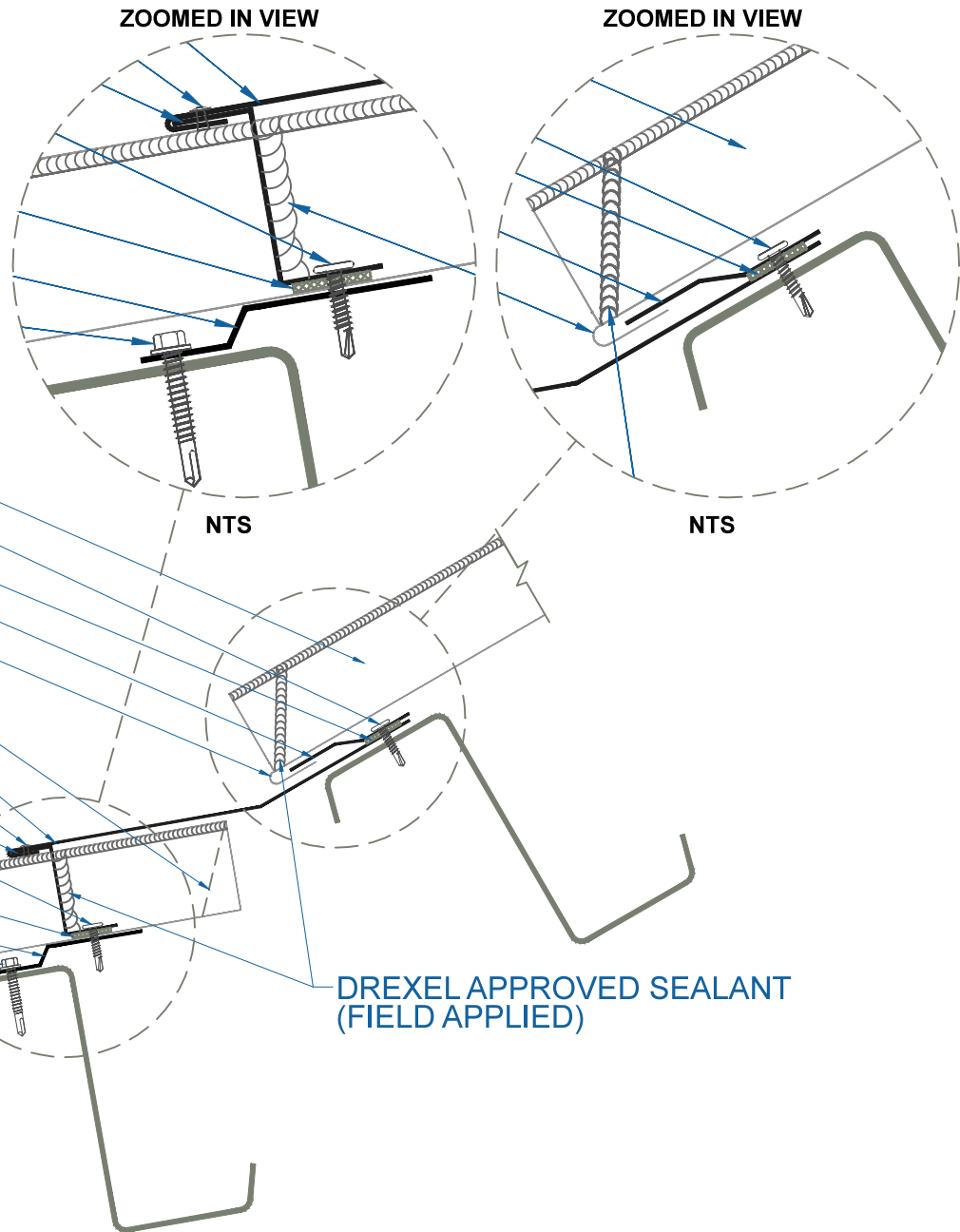

- DMC 200S PANEL
- #10 - 16 x 1" DP3 PHD (12" o.c.)
- D.B. TAPE SEALANT
- OFFSET CLEAT FLASHING
- FIELD CUT & HEM PANEL 180°
- BOX END OF PANEL
- TRANSITION FLASHING
- 1/8" - #43 POP RIVET (12" o.c.)
- Z-CLOSURE
- #10 - 16 x 1" DP3 PHD (5 PER PANEL)
- D.B. TAPE SEALANT
- EAVE PLATE 16GA
- 1/4 - 14 x 1 1/2" DP3 SD/NW (12" o.c.)
- DMC 200S PANEL

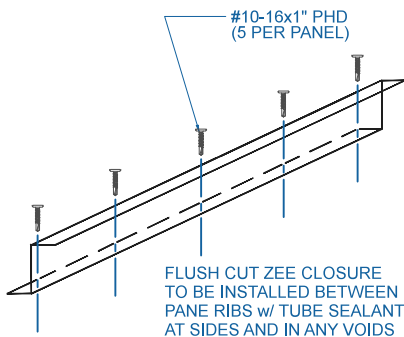

TRANSITION

SCALE: 3" = 1'-0"

EFFECTIVE DATE: 12-12-12
SUBJECT TO CHANGE WITHOUT NOTICE

DMC 200S - OPEN FRAMING

ZOOMED IN VIEW

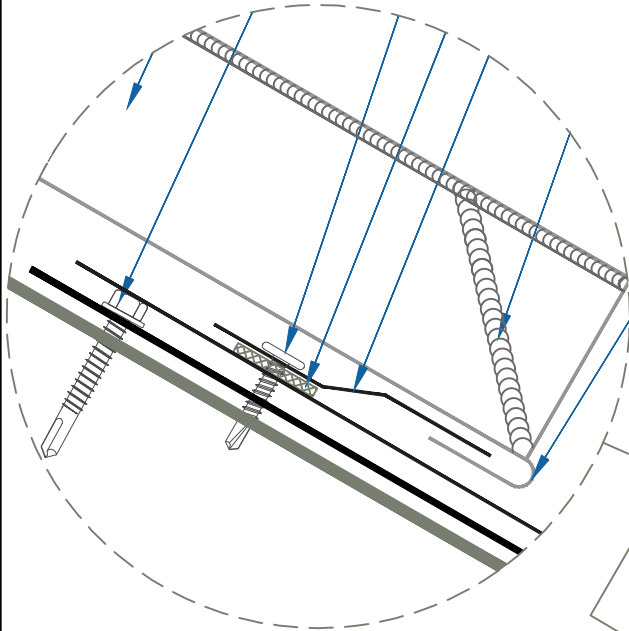

NTS

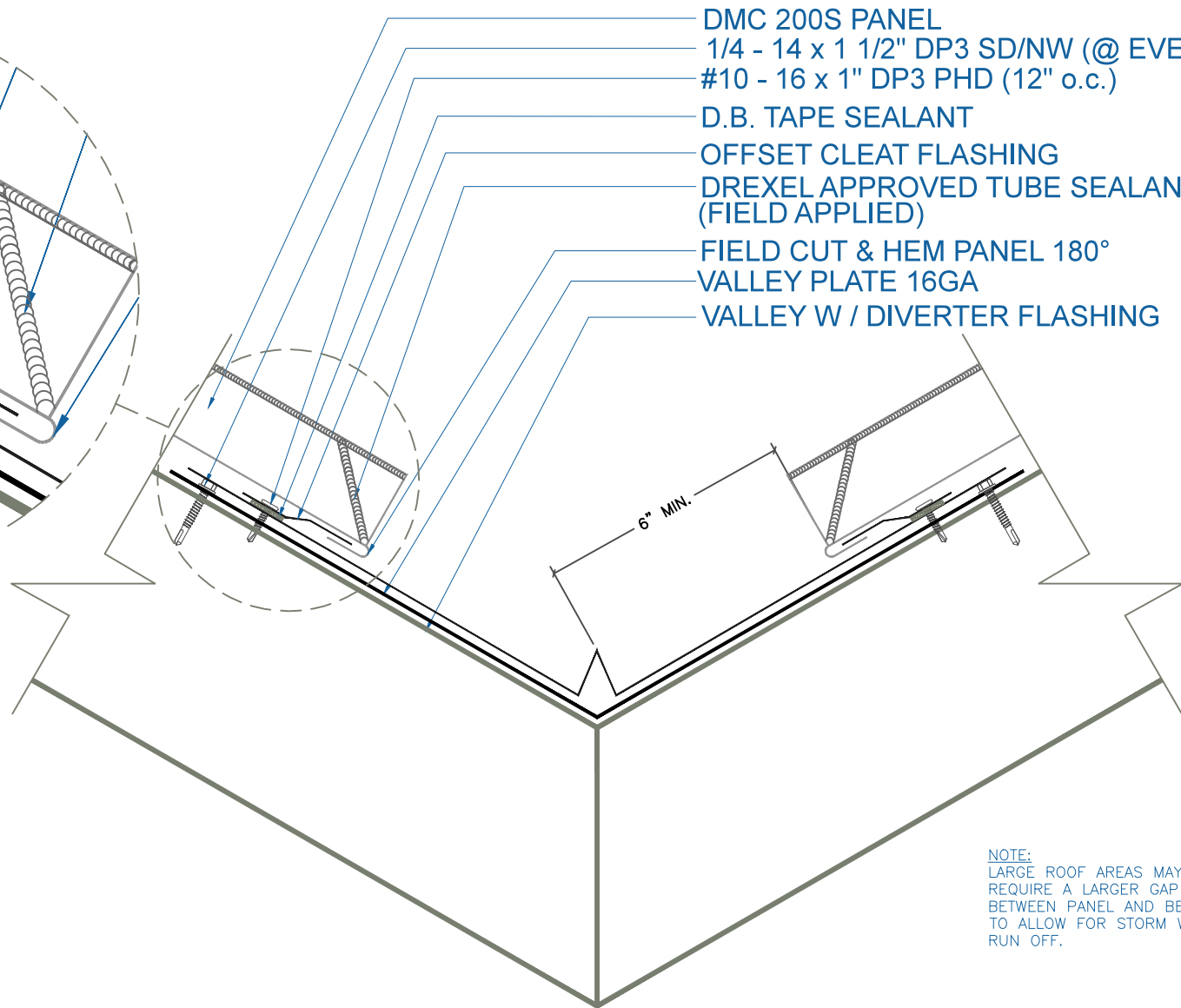

NOTE:
LARGE ROOF AREAS MAY
REQUIRE A LARGER GAP
BETWEEN PANEL AND BEND
TO ALLOW FOR STORM WATER
RUN OFF.

EFFECTIVE DATE: 12-12-12
SUBJECT TO CHANGE WITHOUT NOTICE

VALLEY W / DIVERTER

SCALE: 3" = 1'-0"

DrexelMetals
Roofing Systems + Custom Fabrication



DMC 200S - OPEN FRAMING

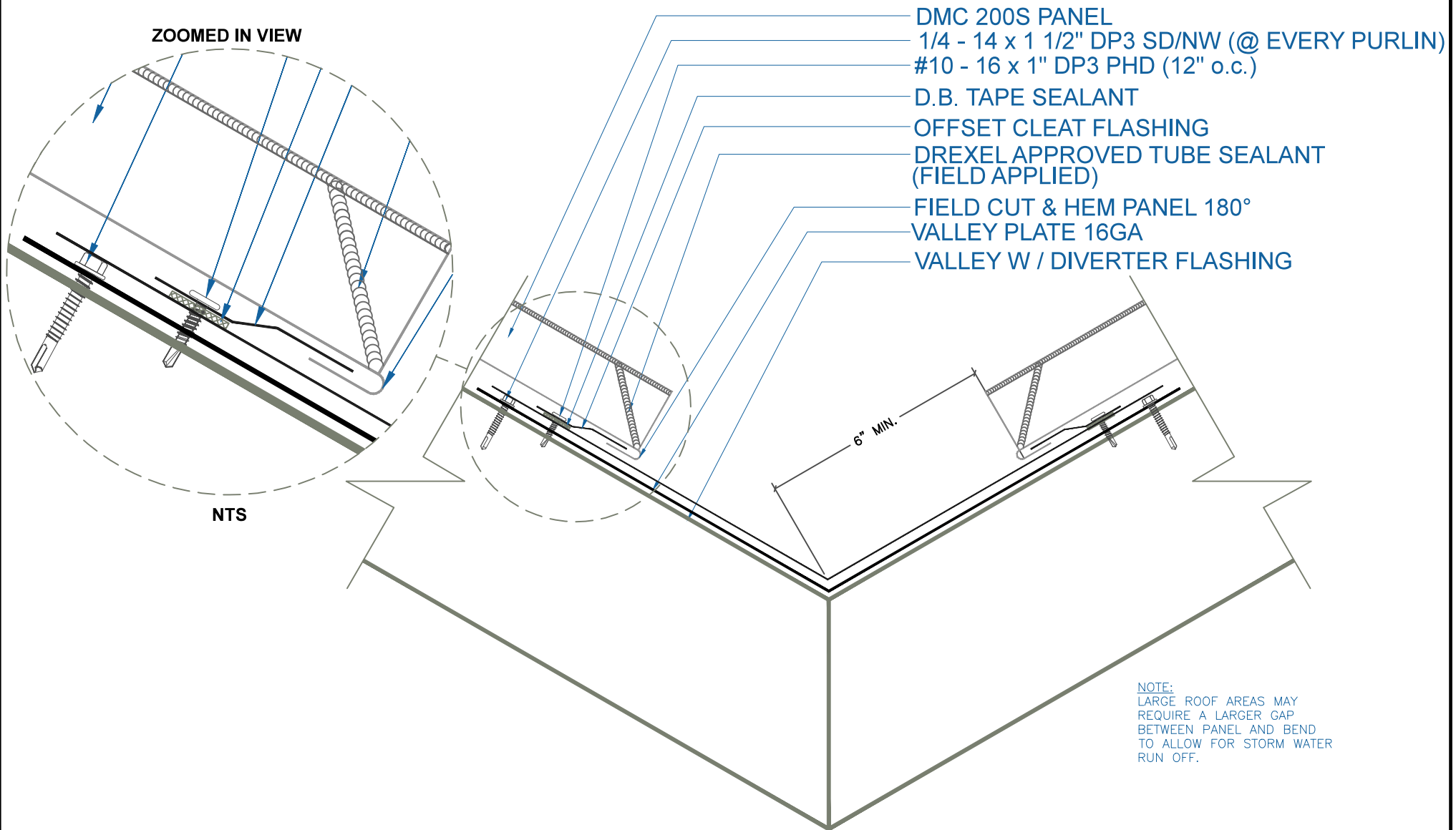

ZOOMED IN VIEW

NTS

VALLEY W/O DIVERTER

SCALE: 3" = 1'-0"

DrexelMetals
Roofing Systems + Custom Fabrication



EFFECTIVE DATE: 12-12-12
SUBJECT TO CHANGE WITHOUT NOTICE

DMC 200S - OPEN FRAMING

NOTE:
LARGE ROOF AREAS MAY
REQUIRE A LARGER GAP
BETWEEN PANEL AND
BEND TO ALLOW FOR
STORM WATER RUN OFF.

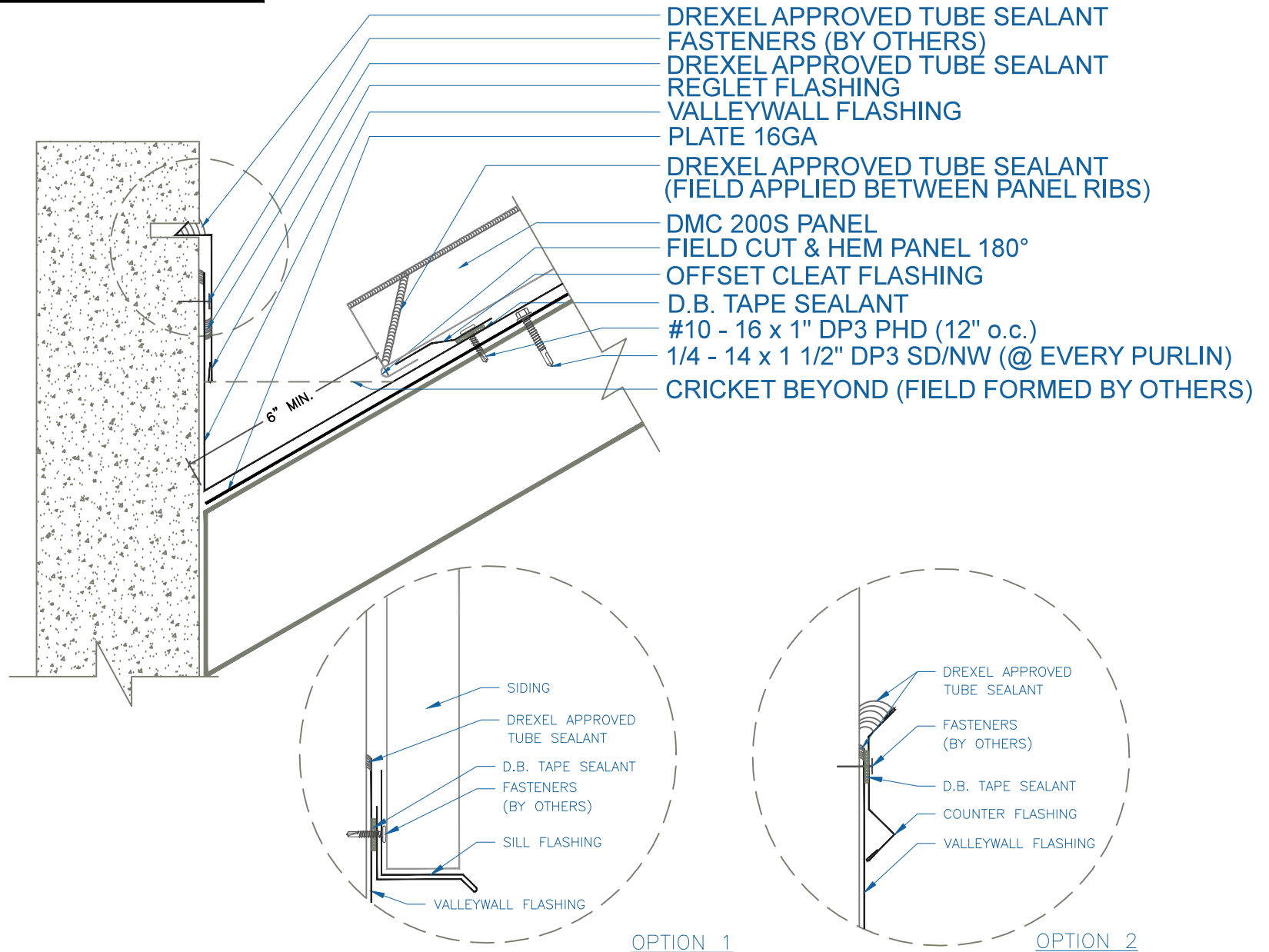

OPTION 1

OPTION 2

VALLEYWALL

SCALE: 3" = 1'-0"

DrexelMetals
Roofing Systems + Custom Fabrication



EFFECTIVE DATE: 12-12-12
SUBJECT TO CHANGE WITHOUT NOTICE

DMC 200S - OPEN FRAMING

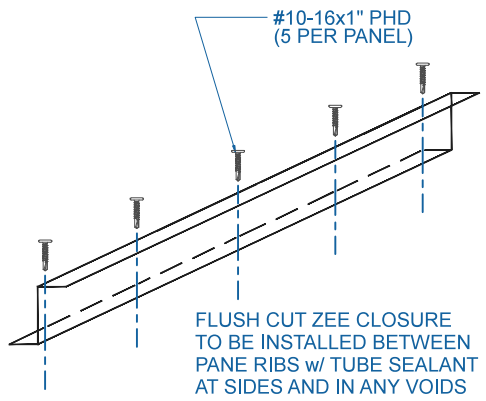
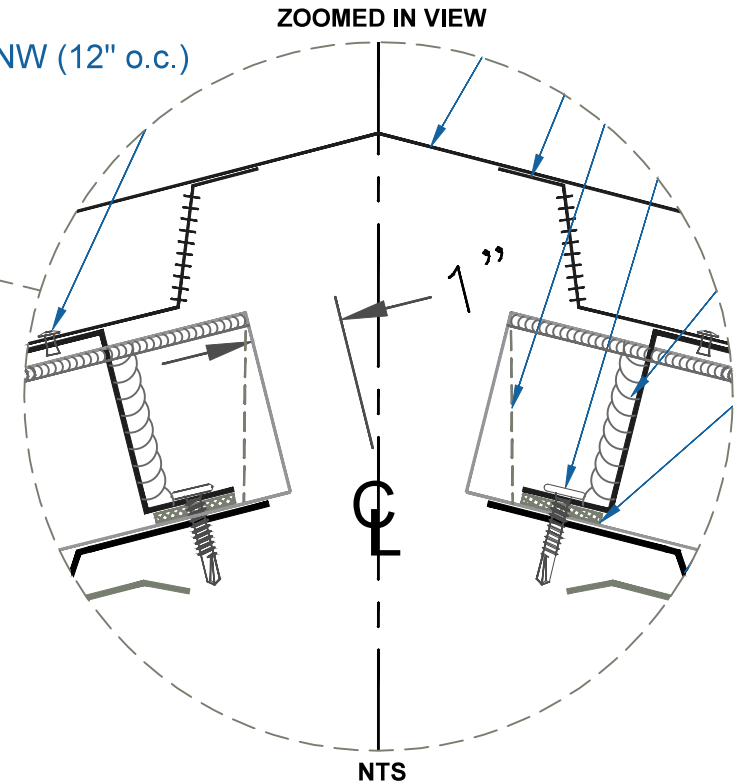
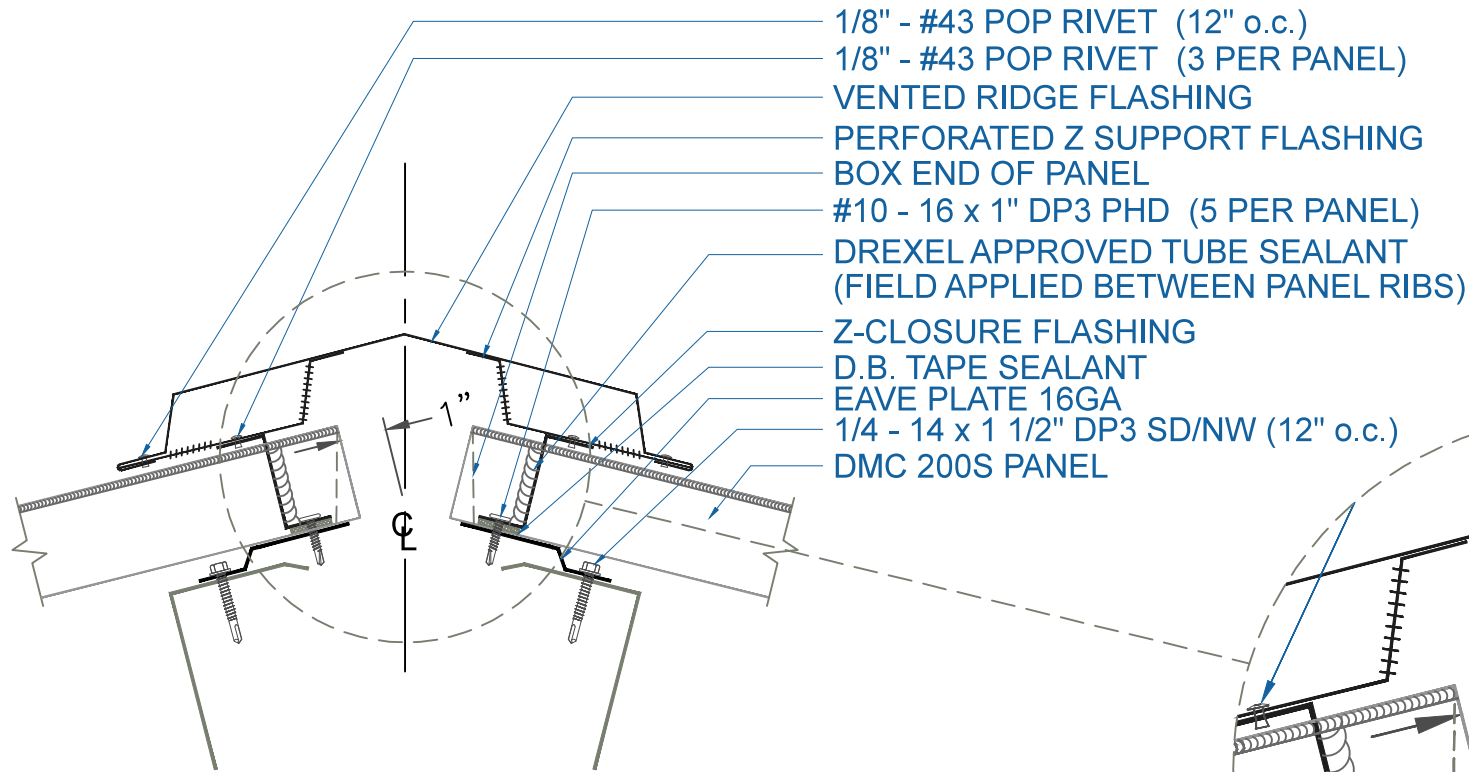

EFFECTIVE DATE: 12-12-12
 SUBJECT TO CHANGE WITHOUT NOTICE

VENTED RIDGE

SCALE: 3" = 1'-0"