

# DMC150NS - PLYWOOD

- DMC 150NS PANEL
- #10 - 13 x 1" PHW (12" o.c.)
- D.B. TAPE SEALANT
- OFFSET CLEAT FLASHING
- FIELD CUT & HEM PANEL 180°
- BOX END OF PANEL  
(SEE ZEE CLOSURE OPTIONS DETAIL)
- TRANSITION FLASHING
- #10 - 13 x 1" PHW (5 PER PANEL)
- D.B. TAPE SEALANT
- 1/8" - #43 POP RIVET (18" o.c.)
- Z-CLOSURE
- PLYWOOD SUBSTRATE (1/2" MIN.)
- DMC 150NS PANEL
- METSHIELD UNDERLAYMENT

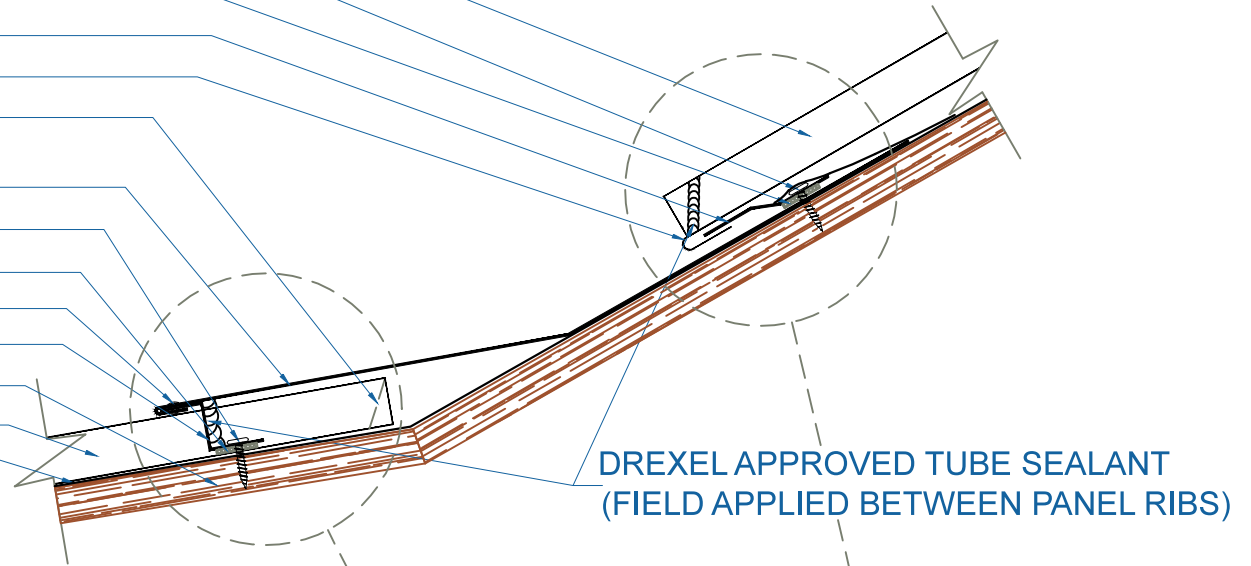

ZOOMED IN VIEW

ZOOMED IN VIEW

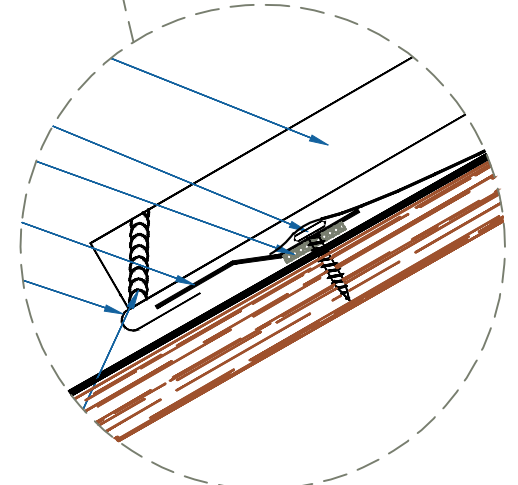
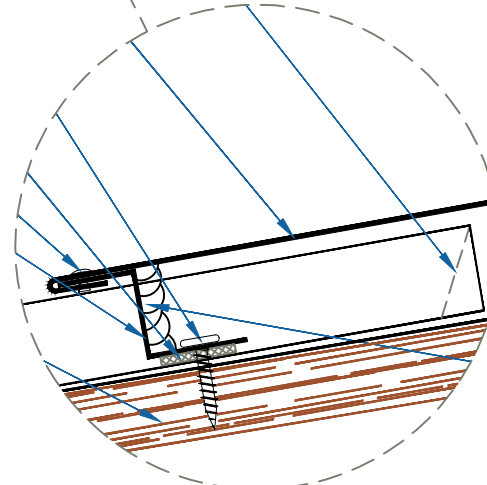
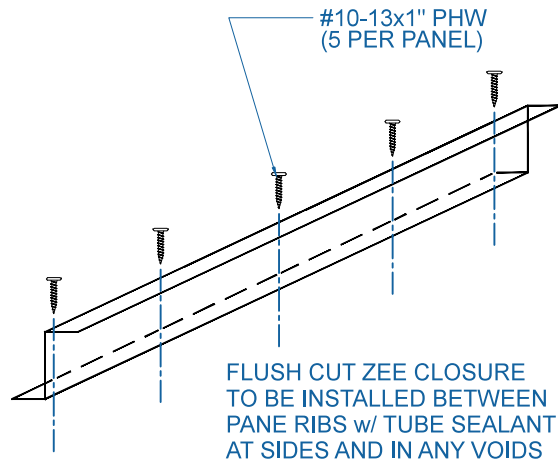

NTS

NTS

## TRANSITION

EFFECTIVE DATE: 02-15-2013  
SUBJECT TO CHANGE WITHOUT NOTICE

SCALE: 3" = 1'-0"