

DRIP EDGE PRINT APPROVAL

ANSI/SPRI ES-1 CERTIFIED -
.040" Aluminum = 410 psf, 24GA Steel = 390 psf

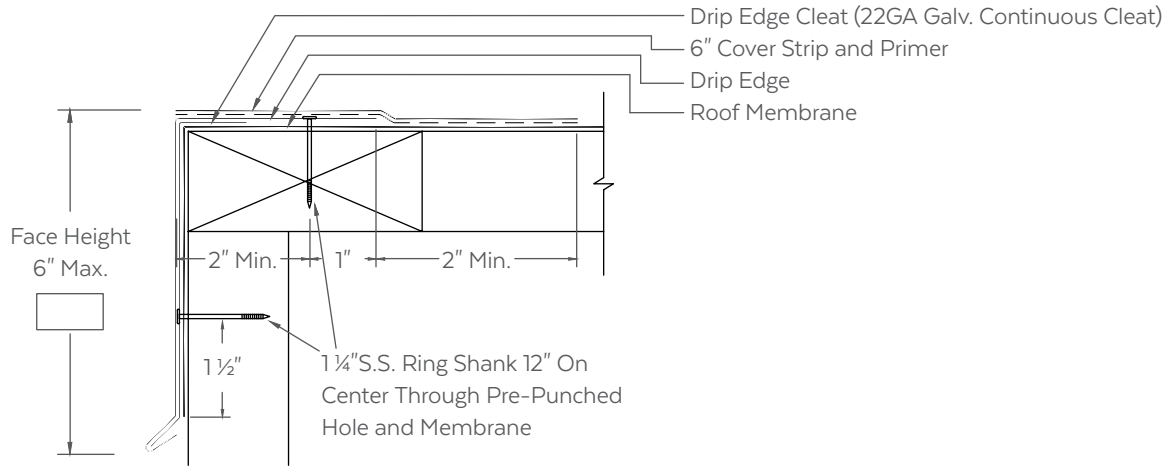

MATERIAL

24GA	.040" AL
22GA	.050" AL
Other:	.063" AL

Finish: _____

Color: _____

QUANTITIES

Lineal Feet (10'-0" Lengths): _____

Outside Miters*: _____ Optional Welded (Surcharge Applies)

Inside Miters*: _____ Optional Welded (Surcharge Applies)

Right End Caps*: _____ Optional Welded (Surcharge Applies)

Left End Caps*: _____ Optional Welded (Surcharge Applies)

*Standard riveted

PROJECT DETAILS

Project: _____

Architect: _____

Roofing Contractor: _____

Representative: _____

PRINT APPROVAL

Architect and/or Contractor shall verify all dimensions, sizes, and quantities, All products to be installed in strict accordance with Drexel's printed instructions.

Effective Date: _____

Drawn By: _____

Approved By: _____