

GRAVEL STOP PRINT APPROVAL

ANSI/SPRI ES-1 CERTIFIED -
.040" Aluminum = 170 psf, 24GA Steel = 180 psf

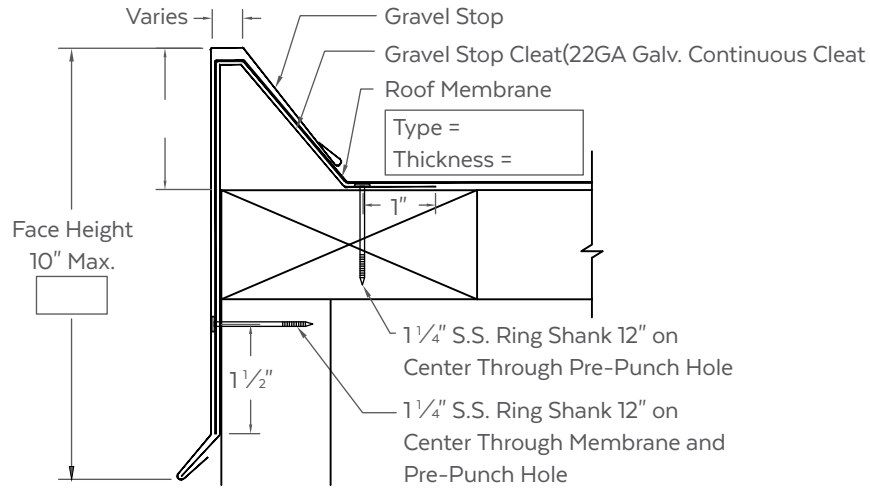

MATERIAL

24GA .040" AL
22GA .050" AL
Other: _____
Finish: _____
Color: _____

QUANTITIES

Lineal Feet (10'-0" Lengths): _____
Outside Miters*: _____ Optional Welded (Surcharge Applies)
Inside Miters*: _____ Optional Welded (Surcharge Applies)
Right End Caps*: _____ Optional Welded (Surcharge Applies)
Left End Caps*: _____ Optional Welded (Surcharge Applies)
Splice Plate Tape Sealant: _____ Optional Sealant (Surcharge Applies)

*Standard riveted

PROJECT DETAILS

Project: _____
Architect: _____
Roofing Contractor: _____
Representative: _____

PRINT APPROVAL

Architect and/or Contractor shall verify all dimensions, sizes, and quantities, All products to be installed in strict accordance with Drexel's printed instructions.

Effective Date: _____

Drawn By: _____

Approved By: _____