

SECURE-LOK FASCIA PRINT APPROVAL

ANSI/SPRI ES-1 CERTIFIED -
8.25": .040" Aluminum = 210 psf, 24GA Steel = 200 psf
ANSI/SPRI ES-1 CERTIFIED -
12.75": .050" Aluminum = 150 psf, 22GA Steel = 150 psf

MATERIAL CODE: 800992

"A"	"B"	Nailers Covered
5¼"	2⅞"	1
6¾"	4⅜"	2
8¼"	5⅞"	3
9¾"	7⅞"	4
10¼"	7⅞"	5
12¾"	10⅜"	6

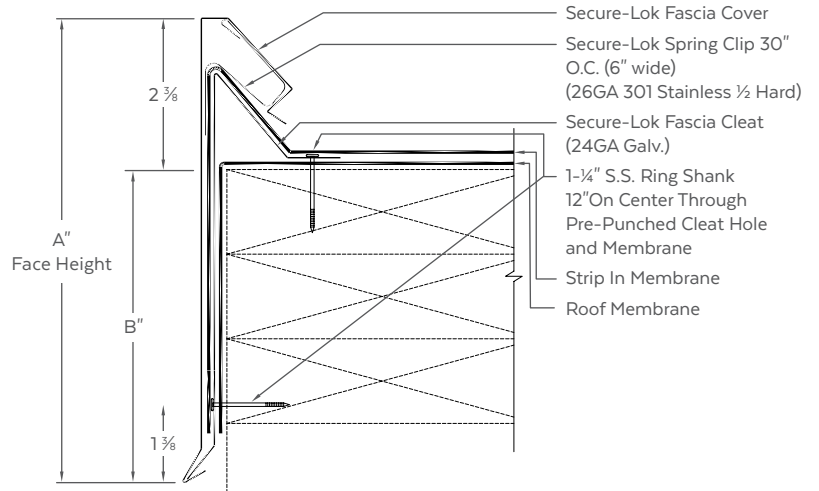

MATERIAL

24GA .040" AL
22GA .050" AL
Other: .063" AL

Finish: _____
Color: _____

QUANTITIES

Lineal Feet (10'-0" Lengths): _____

Outside Miters*: _____ Optional Welded (Surcharge Applies)
Inside Miters*: _____ Optional Welded (Surcharge Applies)
Right End Caps*: _____ Optional Welded (Surcharge Applies)
Left End Caps*: _____ Optional Welded (Surcharge Applies)

* Standard riveted

PROJECT DETAILS

Project: _____
Architect: _____
Roofing Contractor: _____
Representative: _____

PRINT APPROVAL

Architect and/or Contractor shall verify all dimensions, sizes, and quantities, All products to be installed in strict accordance with Drexel's printed instructions.

Effective Date: _____
Drawn By: _____
Approved By: _____