

DMC CAP SEAM - SOLID SUBSTRATE

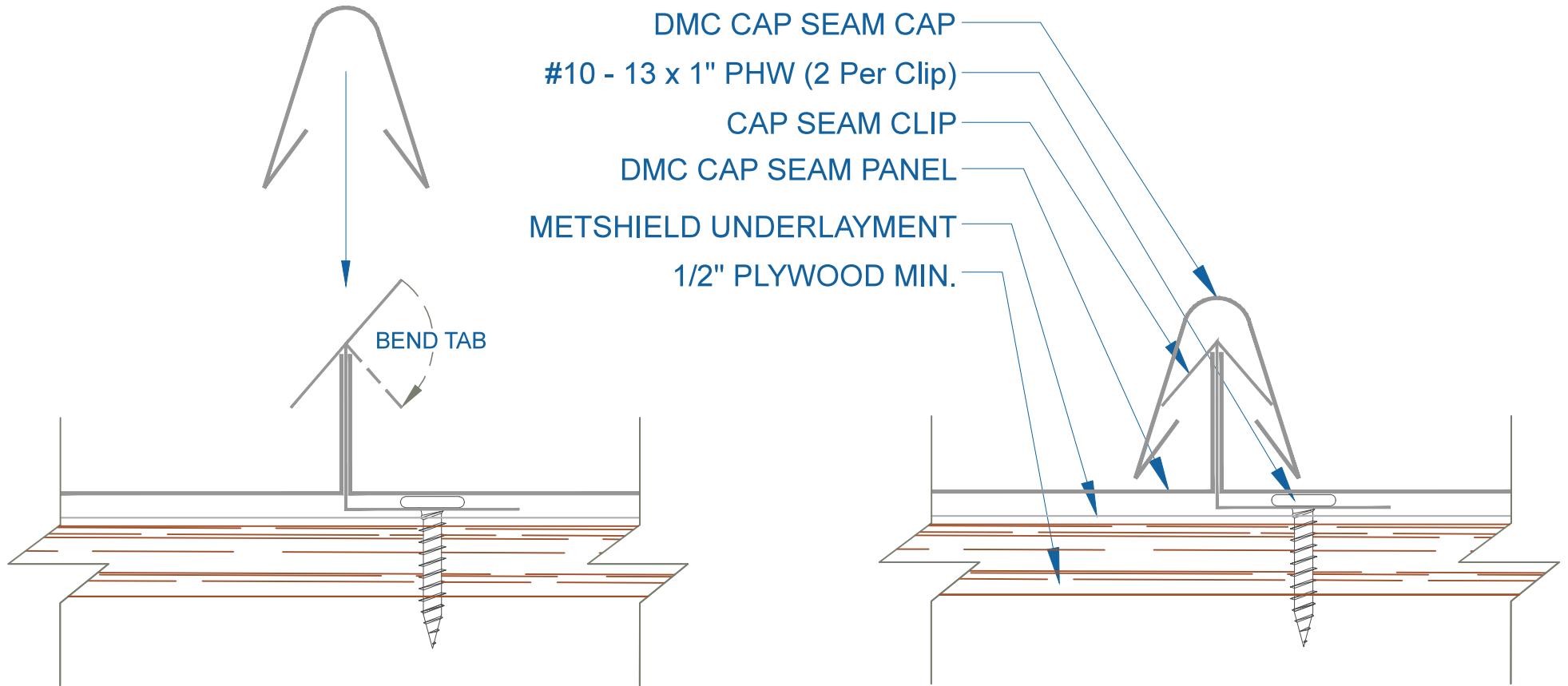

PANEL INSTALLATION

SCALE: NTS

EFFECTIVE DATE: 08-14-2013
SUBJECT TO CHANGE WITHOUT NOTICE

DMC CAP SEAM - PLYWOOD

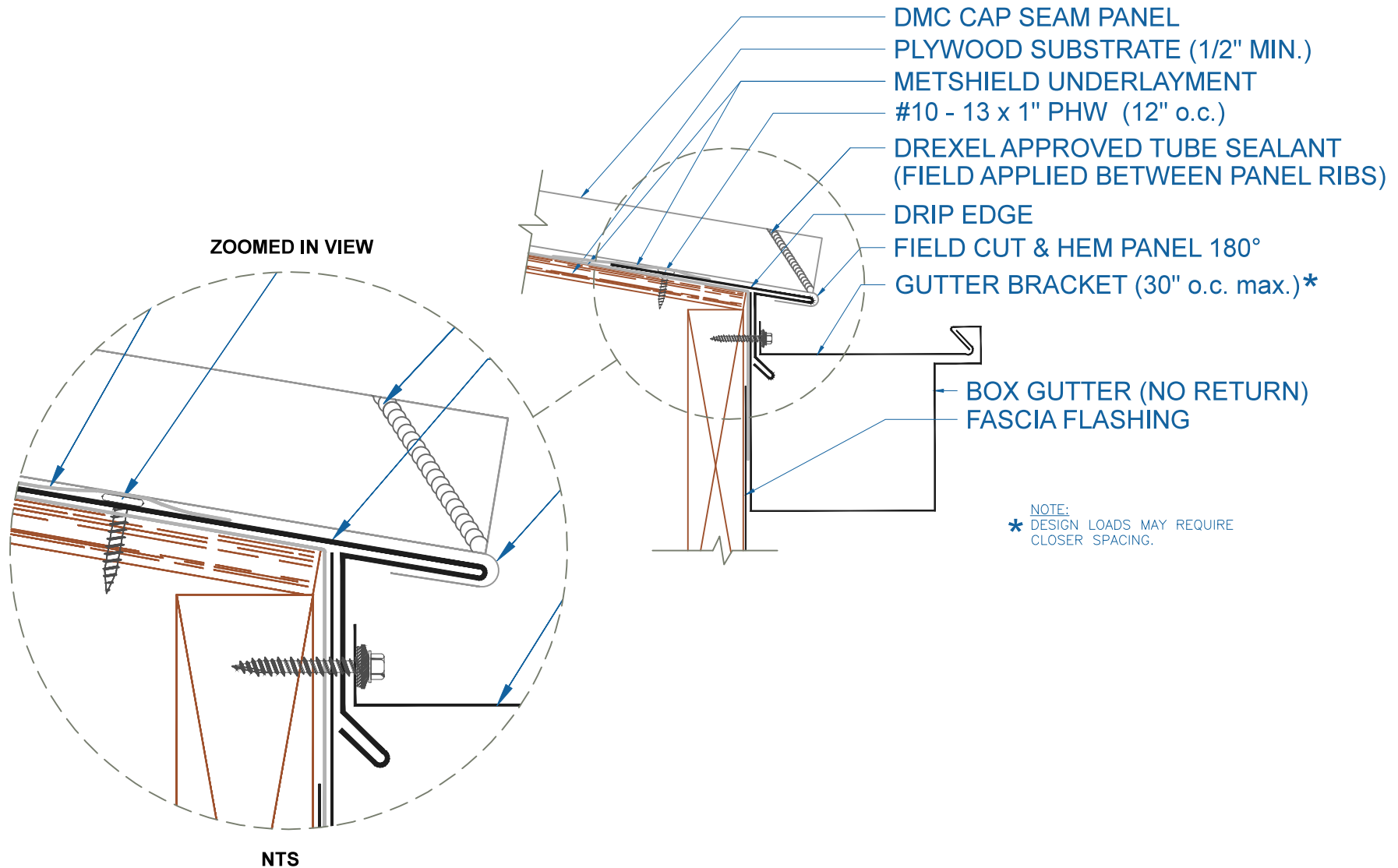

BOX GUTTER w/DRIP EDGE

SCALE: 3" = 1'-0"

EFFECTIVE DATE: 08-13-2013
SUBJECT TO CHANGE WITHOUT NOTICE

DMC CAP SEAM - PLYWOOD

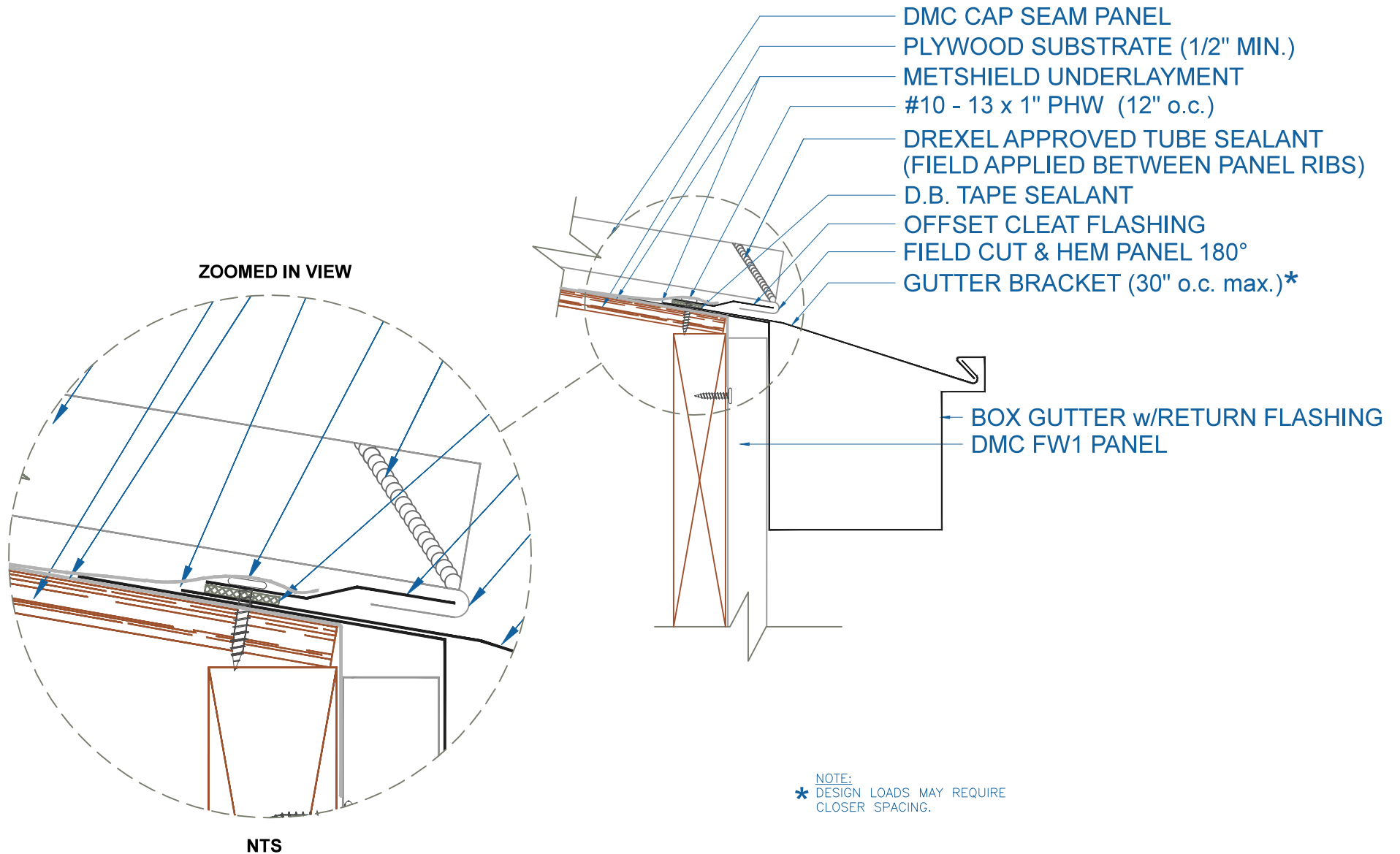

BOX GUTTER w/RETURN

SCALE: 3" = 1'-0"

EFFECTIVE DATE: 08-13-2013
SUBJECT TO CHANGE WITHOUT NOTICE

DMC CAP SEAM - PLYWOOD

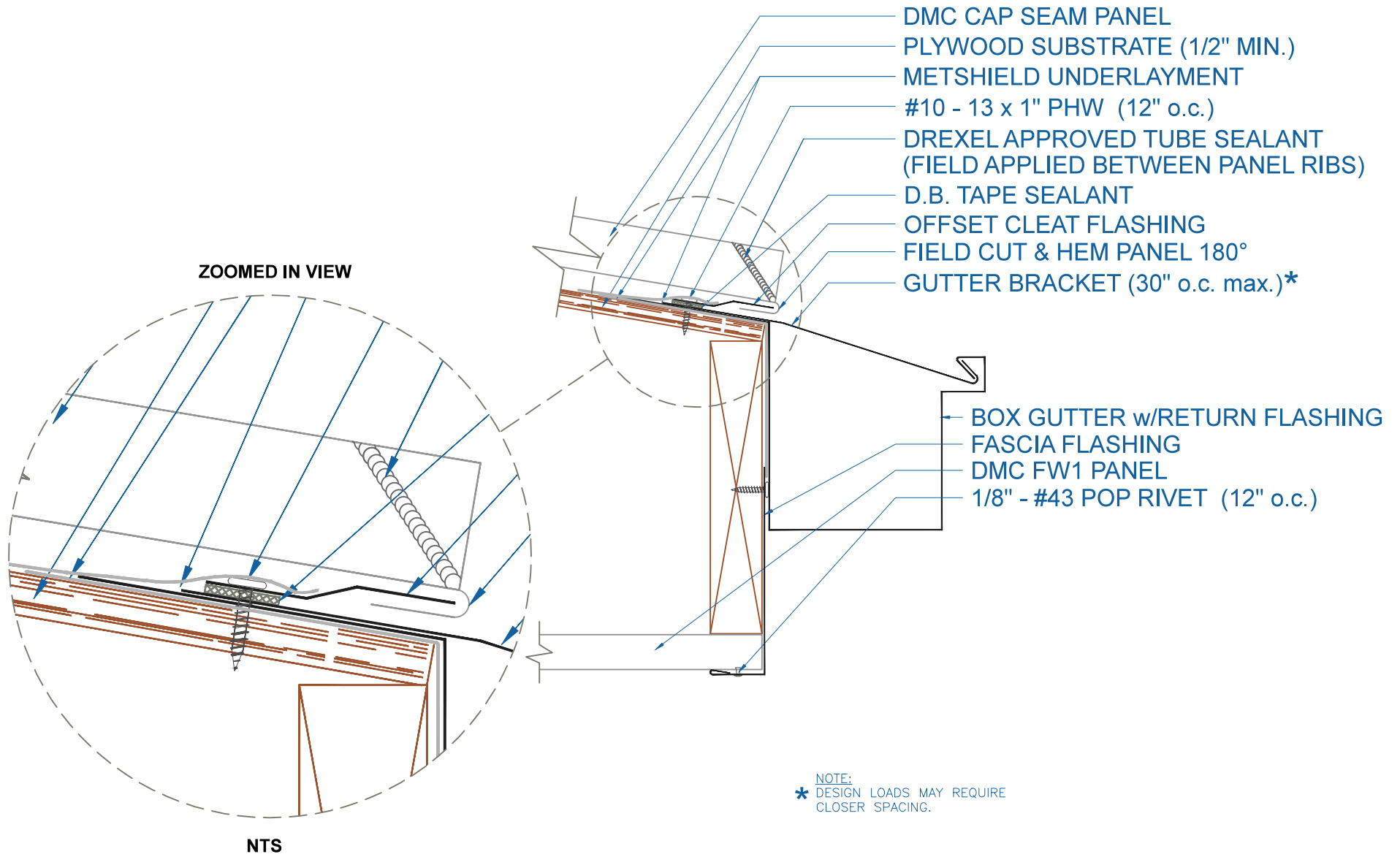

BOX GUTTER - w/RETURN w/SOFFIT

SCALE: 3" = 1'-0"

EFFECTIVE DATE: 08-13-2013
SUBJECT TO CHANGE WITHOUT NOTICE

DrexelMetals
Roofing Systems + Custom Fabrication



DMC CAP SEAM - PLYWOOD

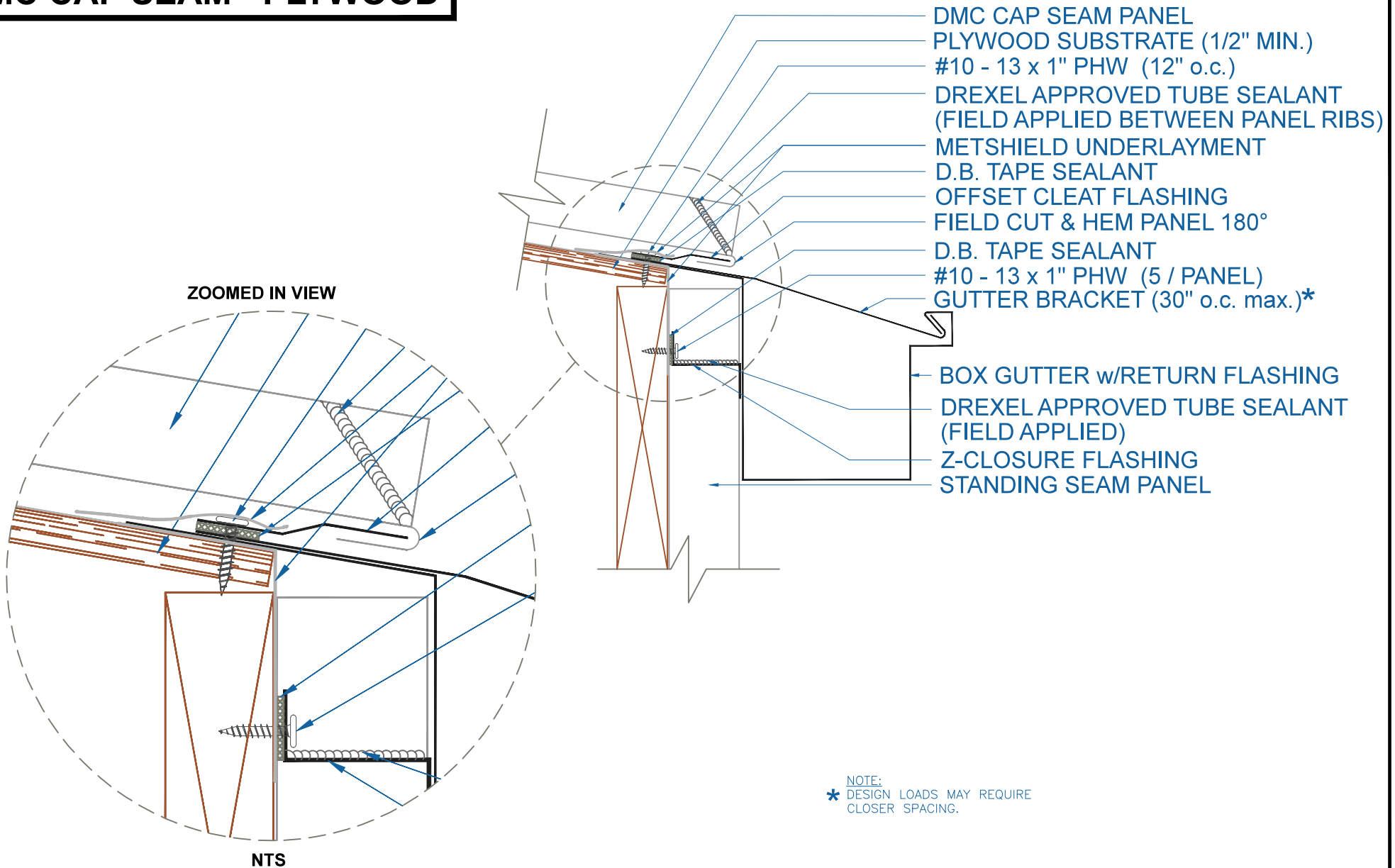

BOX GUTTER w/RETURN w/STANDING SEAM PANEL

SCALE: 3" = 1'-0"

EFFECTIVE DATE: 08-13-2013
SUBJECT TO CHANGE WITHOUT NOTICE

DMC CAP SEAM - PLYWOOD

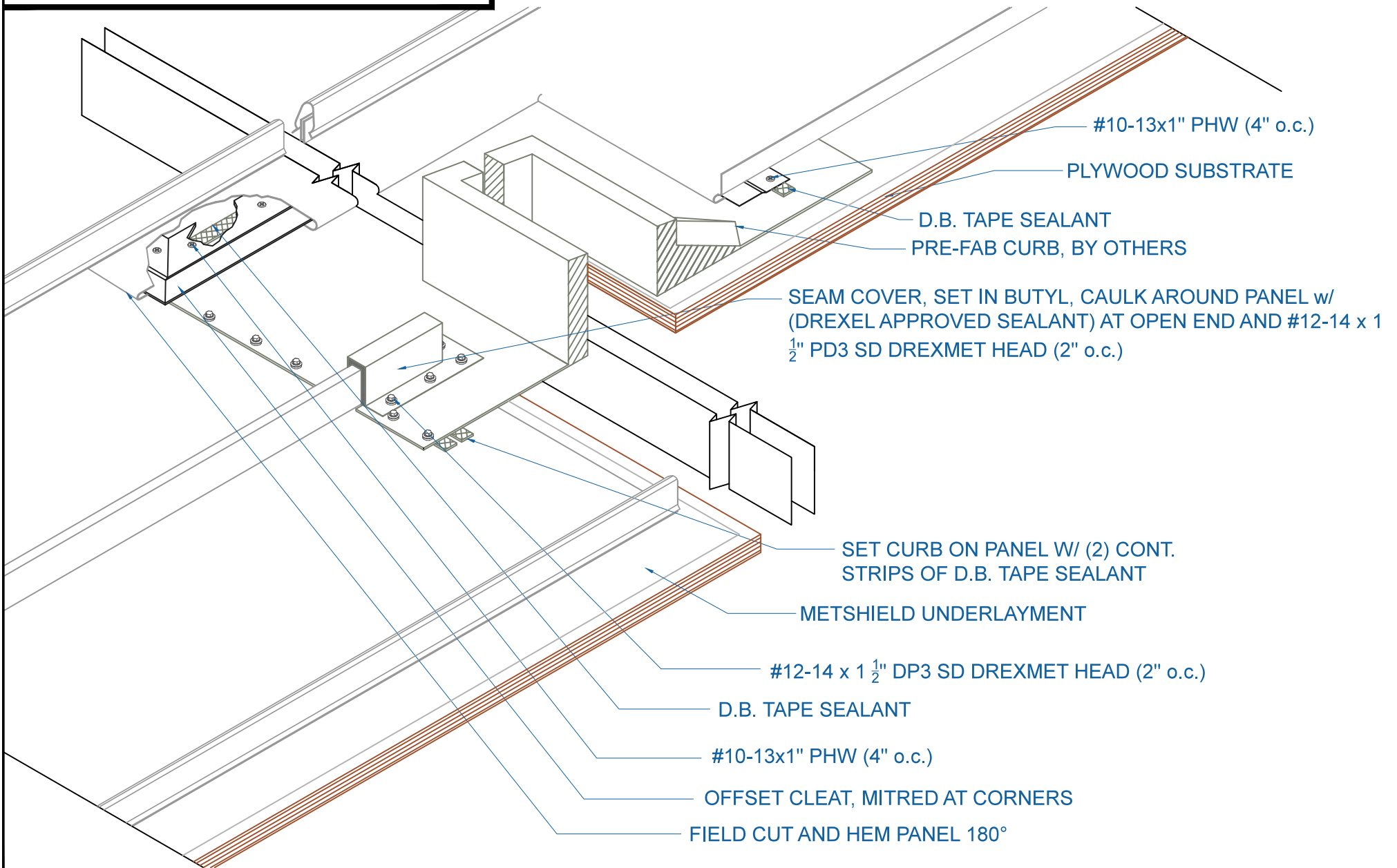

EFFECTIVE DATE: 08-14-2013
SUBJECT TO CHANGE WITHOUT NOTICE

CURB DETAIL

SCALE: NTS

DMC CAP SEAM - PLYWOOD

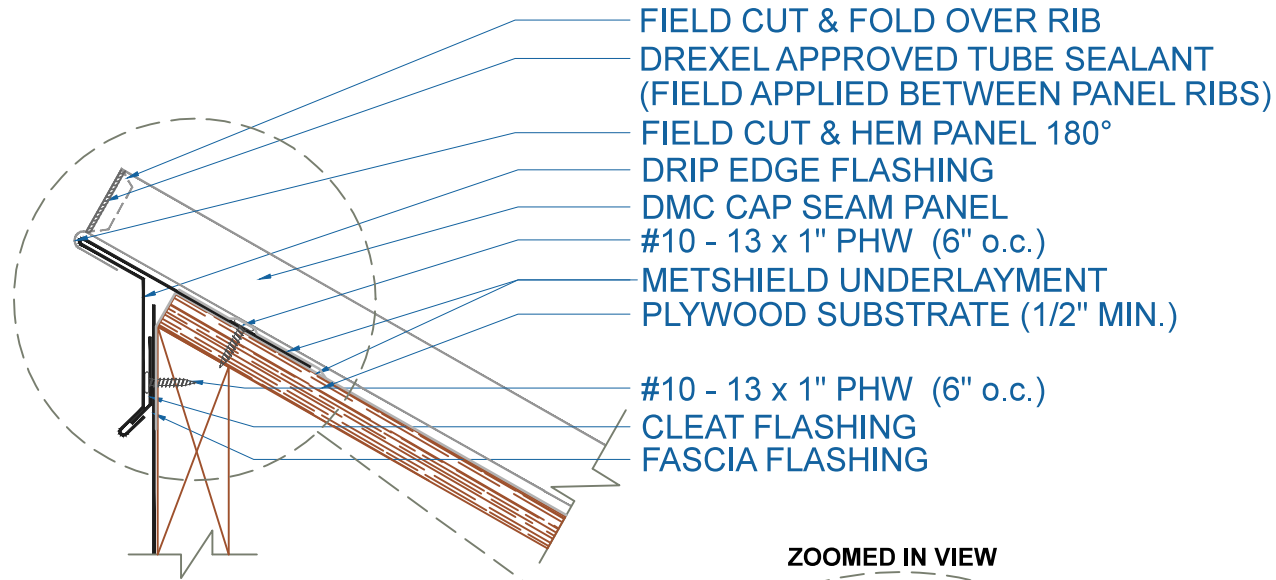

ZOOMED IN VIEW

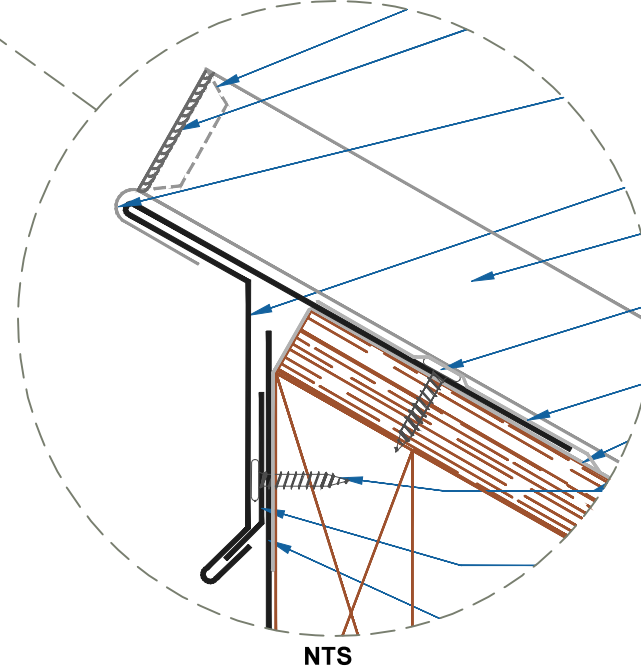

PEAK w/DRIP EDGE

SCALE: 3" = 1'-0"

EFFECTIVE DATE: 08-13-2013
SUBJECT TO CHANGE WITHOUT NOTICE

DrexelMetals
Roofing Systems + Custom Fabrication



DMC CAP SEAM - PLYWOOD

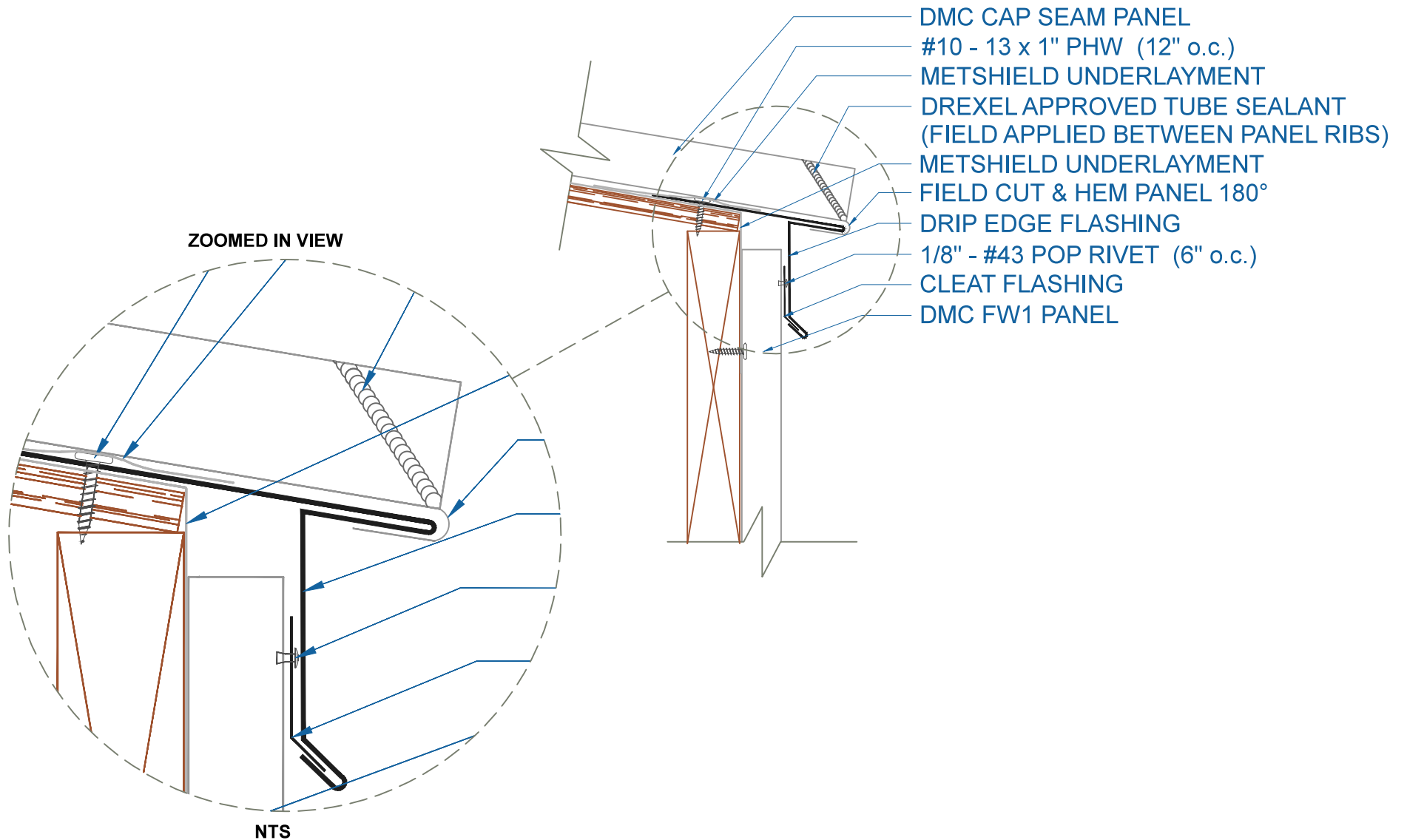

DRIP EDGE w/FLUSH PANEL

SCALE: 3" = 1'-0"

EFFECTIVE DATE: 08-14-2013
SUBJECT TO CHANGE WITHOUT NOTICE

DMC CAP SEAM - PLYWOOD

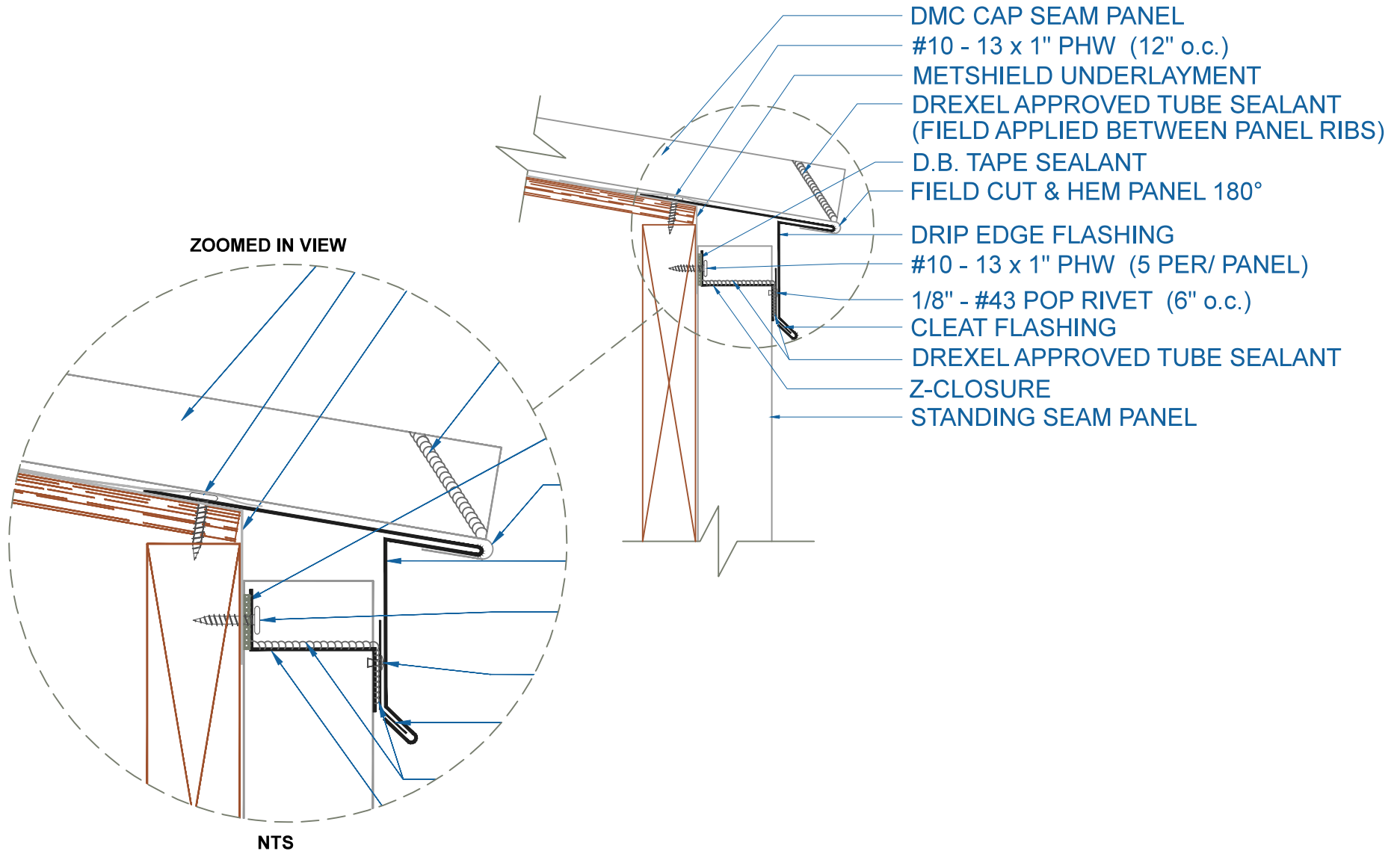

DRIP EDGE w/STANDING SEAM PANEL

EFFECTIVE DATE: 08-14-2013
SUBJECT TO CHANGE WITHOUT NOTICE

SCALE: 3" = 1'-0"

DMC CAP SEAM - PLYWOOD

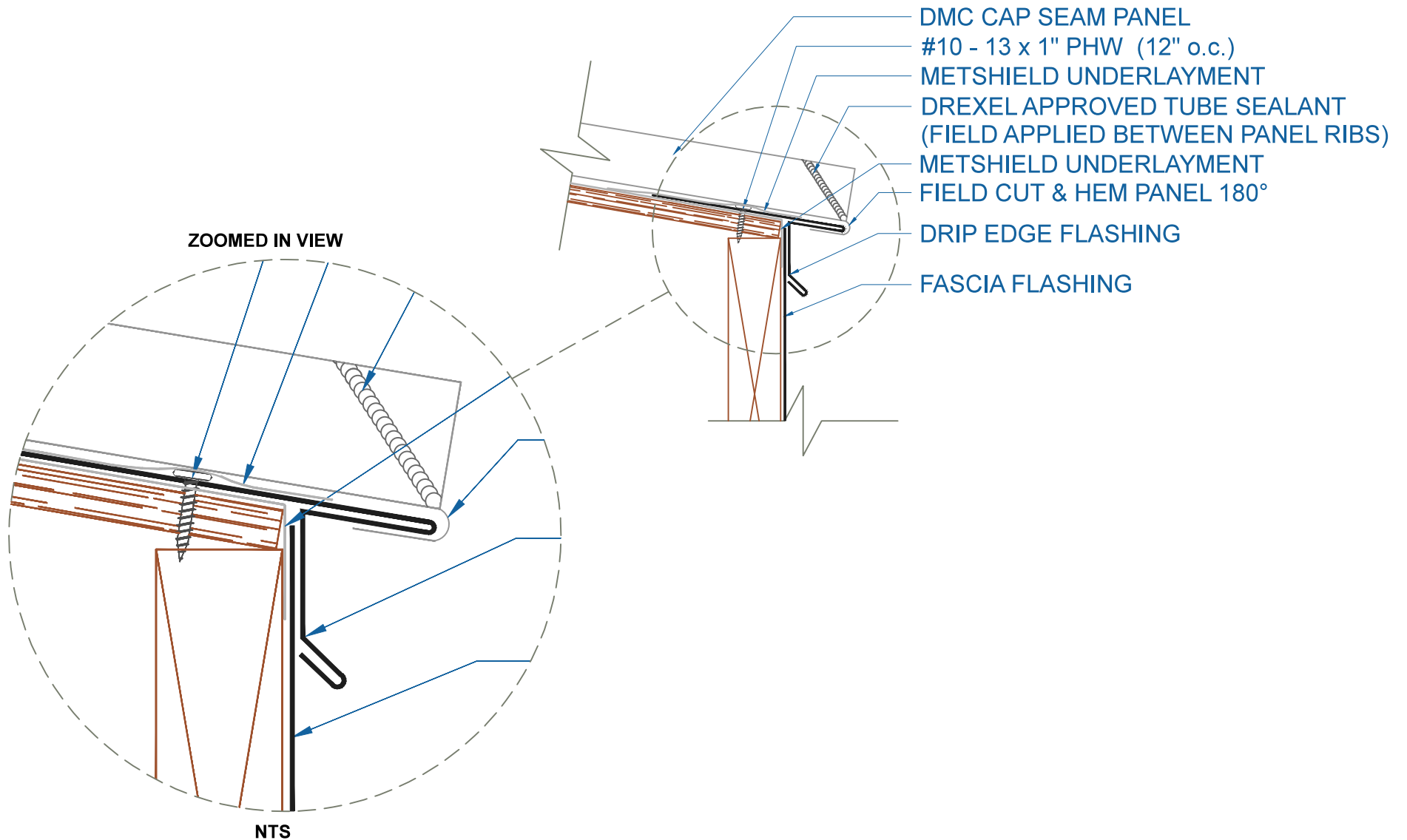

EFFECTIVE DATE: 08-14-2013
SUBJECT TO CHANGE WITHOUT NOTICE

DRIP EDGE

SCALE: 3" = 1'-0"

DMC CAP SEAM - PLYWOOD

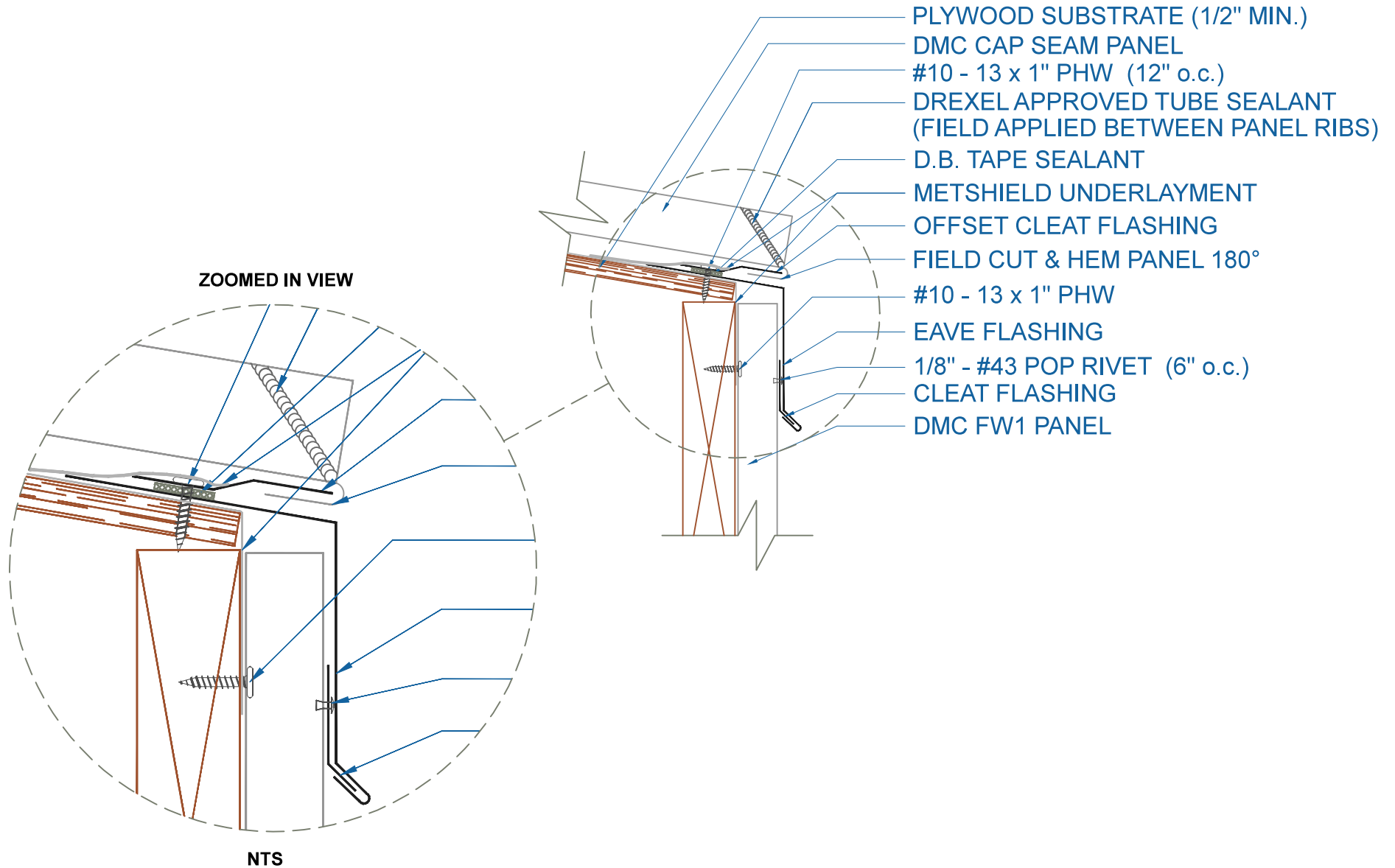

EFFECTIVE DATE: 08-14-2013
 SUBJECT TO CHANGE WITHOUT NOTICE

EAVE w/FLUSH PANEL

SCALE: 3" = 1'-0"

DMC CAP SEAM - PLYWOOD

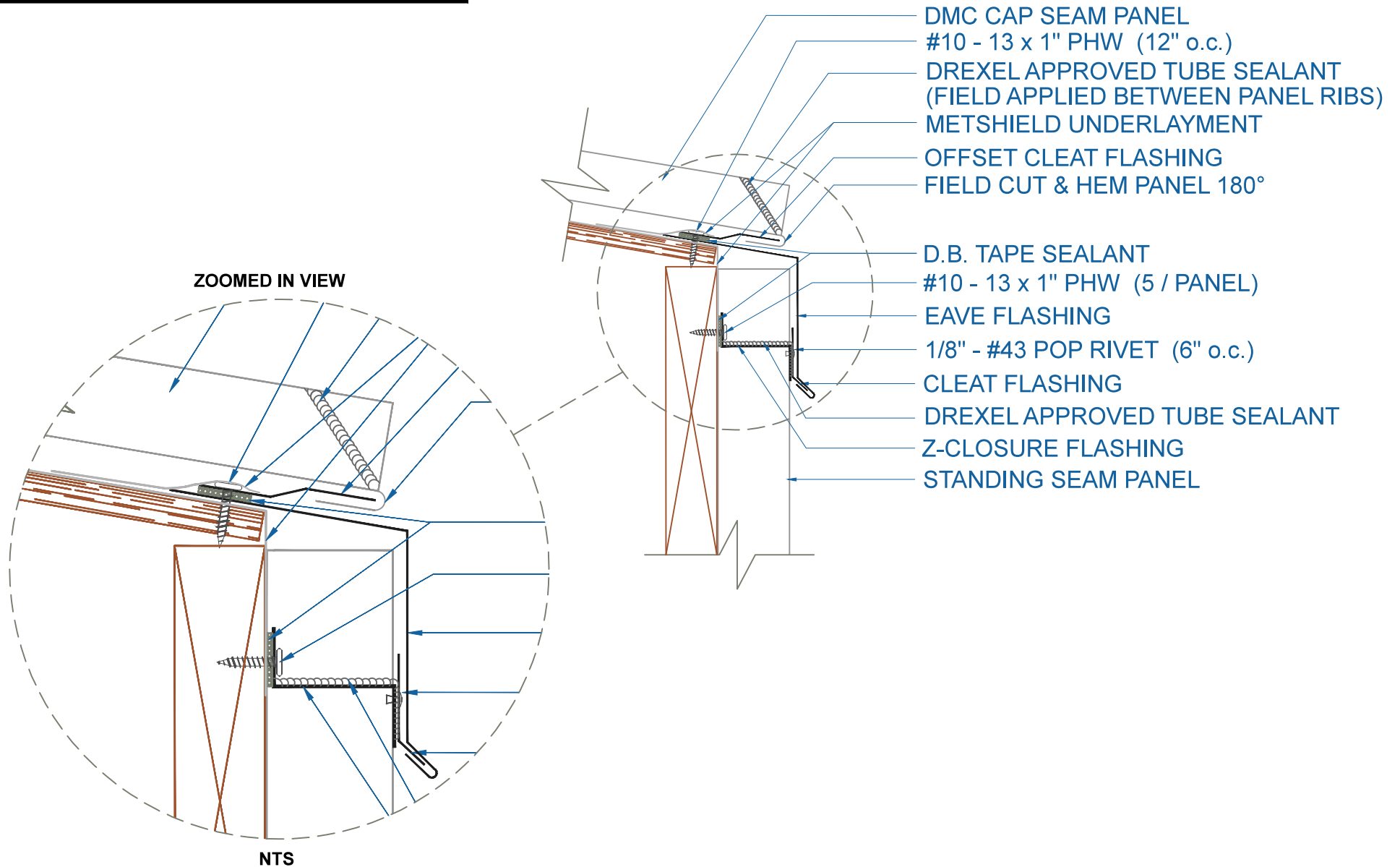

EAVE w/STANDING SEAM PANEL

SCALE: 3" = 1'-0"

EFFECTIVE DATE: 08-14-2013
SUBJECT TO CHANGE WITHOUT NOTICE

DrexelMetals
Roofing Systems + Custom Fabrication



DMC CAP SEAM - PLYWOOD

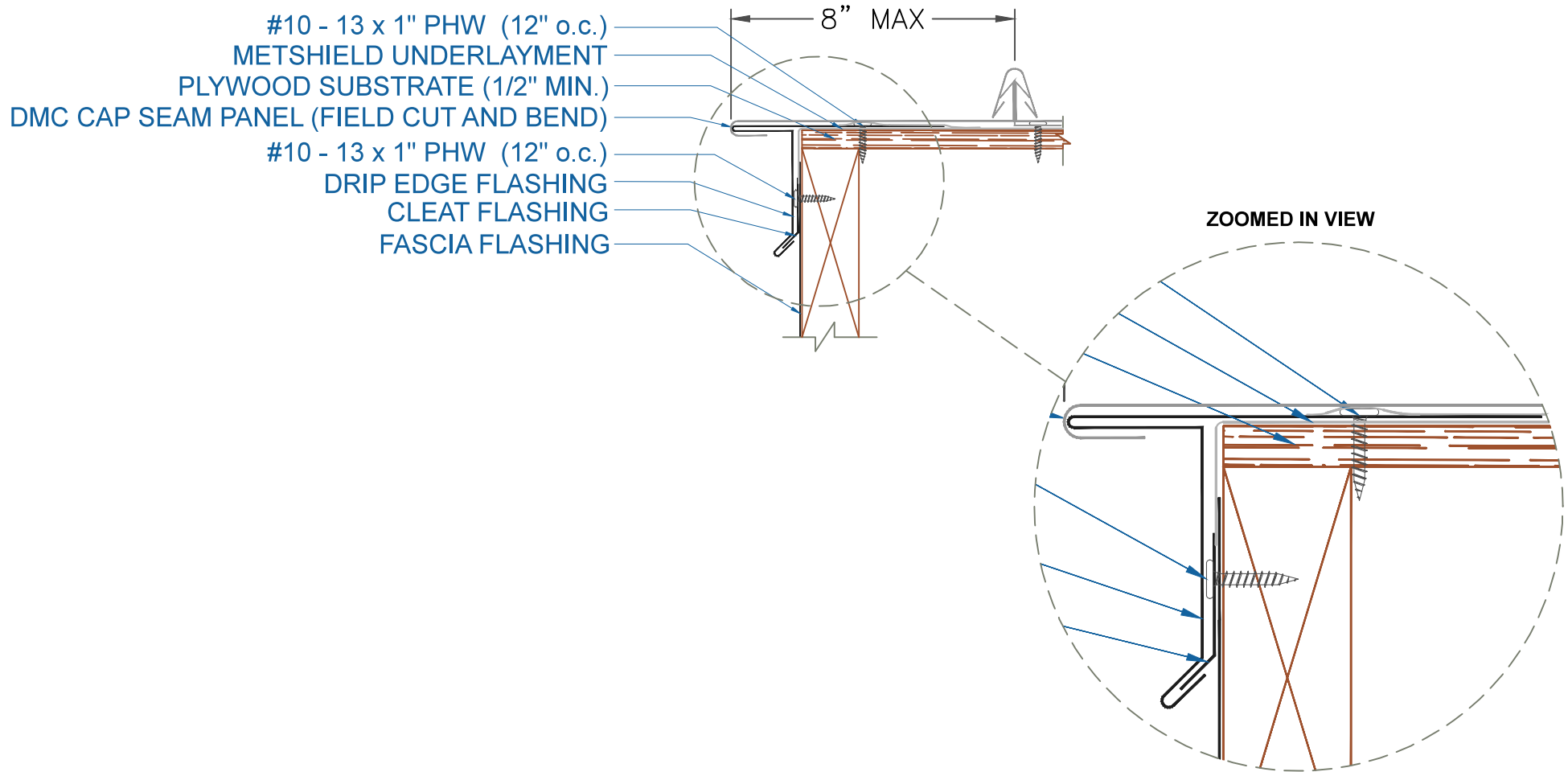

GABLE w/DRIP EDGE

EFFECTIVE DATE: 08-14-2013
SUBJECT TO CHANGE WITHOUT NOTICE

SCALE: 3" = 1'-0"



DMC CAP SEAM - PLYWOOD

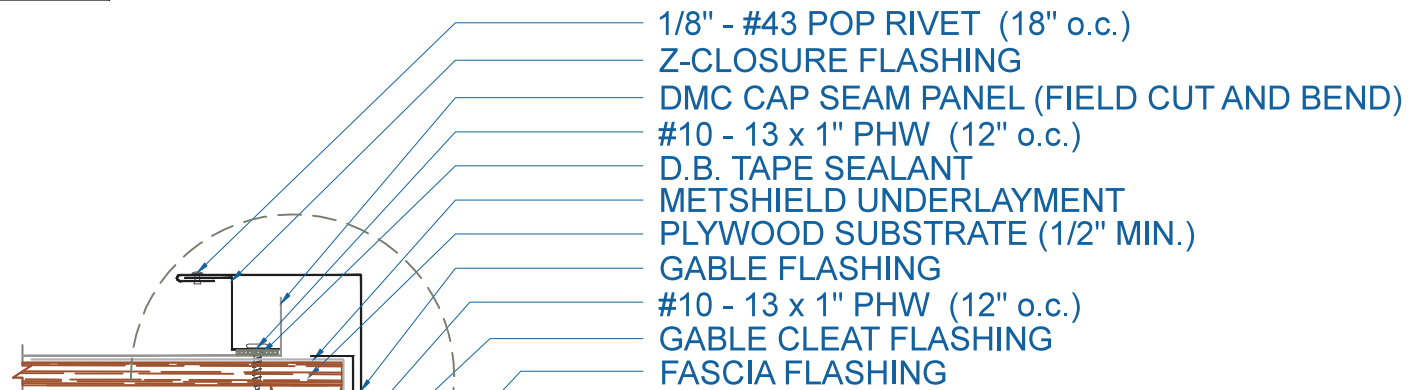

ZOOMED IN VIEW

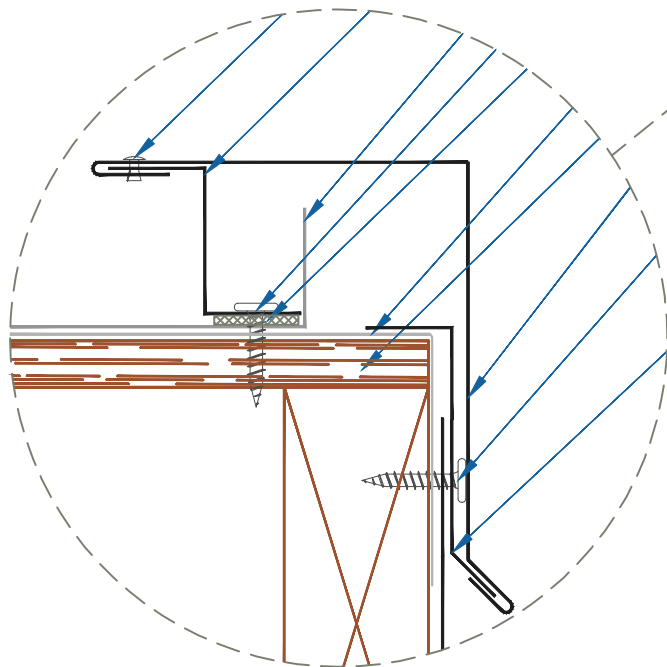

NTS

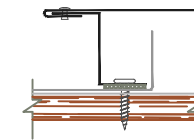

ON MODULE

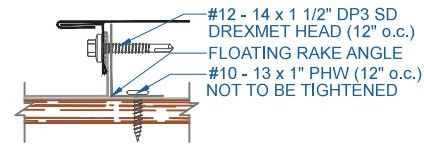

FLOATING GABLE

EFFECTIVE DATE: 08-14-2013
 SUBJECT TO CHANGE WITHOUT NOTICE

GABLE
 SCALE: 3" = 1'-0"

DMC CAP SEAM - PLYWOOD

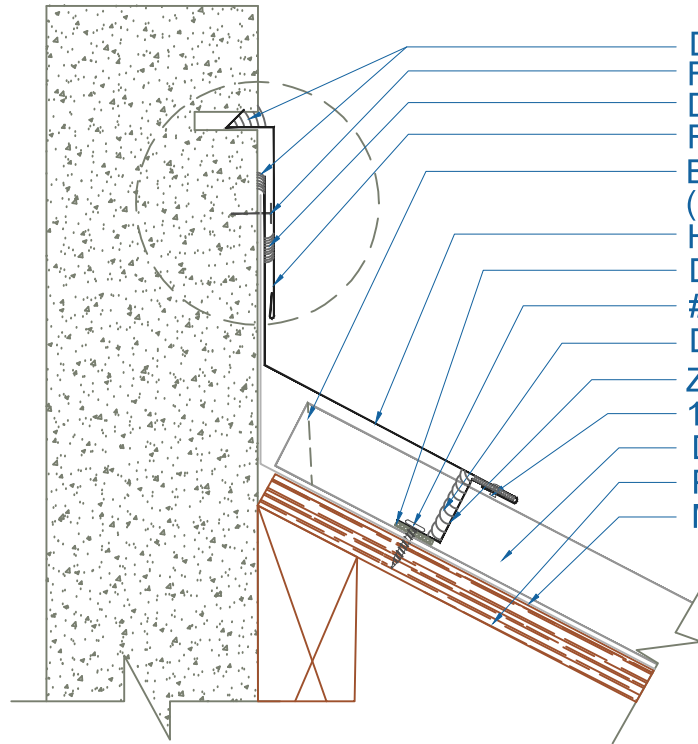

- DREXEL APPROVED TUBE SEALANT
- FASTENERS (BY OTHERS)
- DREXEL APPROVED TUBE SEALANT
- REGLET FLASHING
- BOX END OF PANEL
(SEE ZEE CLOSURE OPTIONS DETAIL)
- HEADWALL FLASHING
- D.B. TAPE SEALANT
- #10 - 13 x 1" PHW (5 PER PANEL)
- DREXEL APPROVED TUBE SEALANT
- Z-CLOSURE FLASHING
- 1/8" - #43 POP RIVET (18" o.c.)
- DMC CAP SEAM PANEL
- PLYWOOD SUBSTRATE (1/2" MIN.)
- METSHIELD UNDERLAYMENT

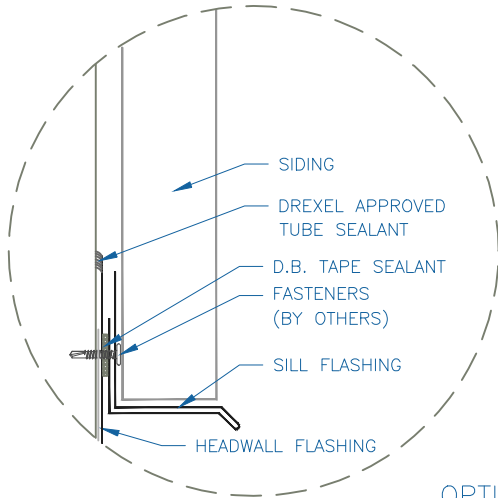

OPTION 1

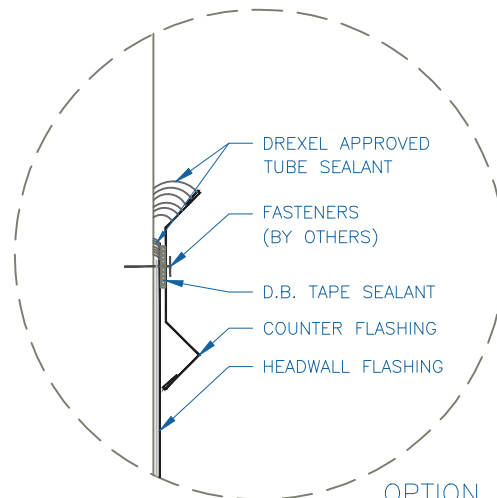

OPTION 2

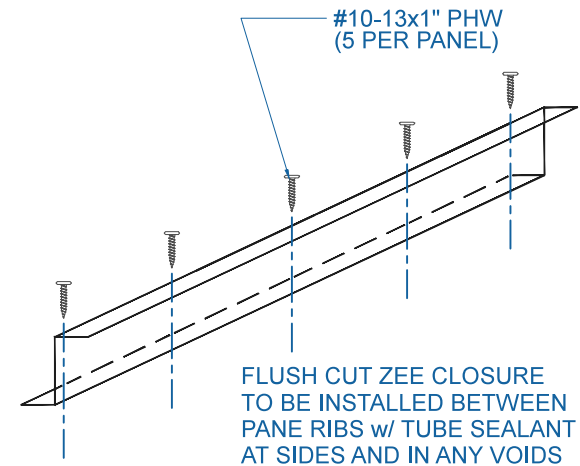

EFFECTIVE DATE: 08-14-2013
SUBJECT TO CHANGE WITHOUT NOTICE

HEADWALL

SCALE: 3" = 1'-0"

DMC CAP SEAM - PLYWOOD

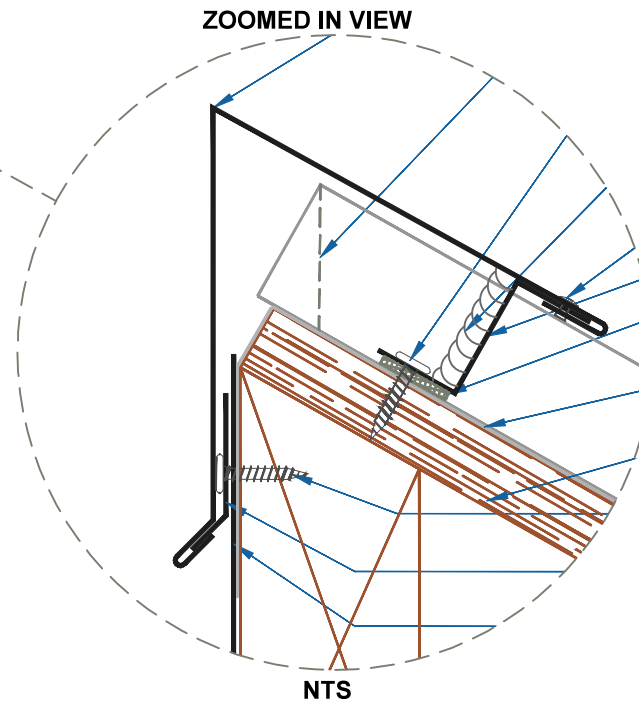
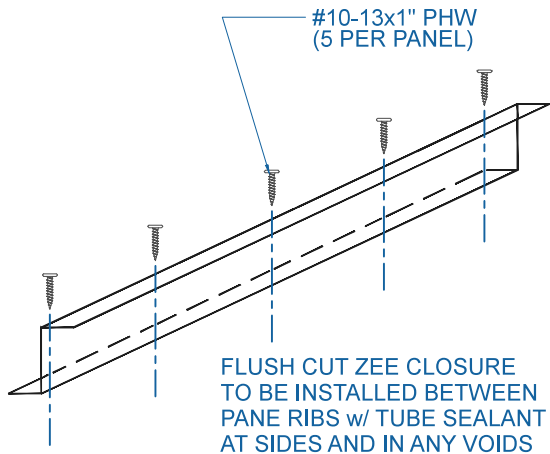
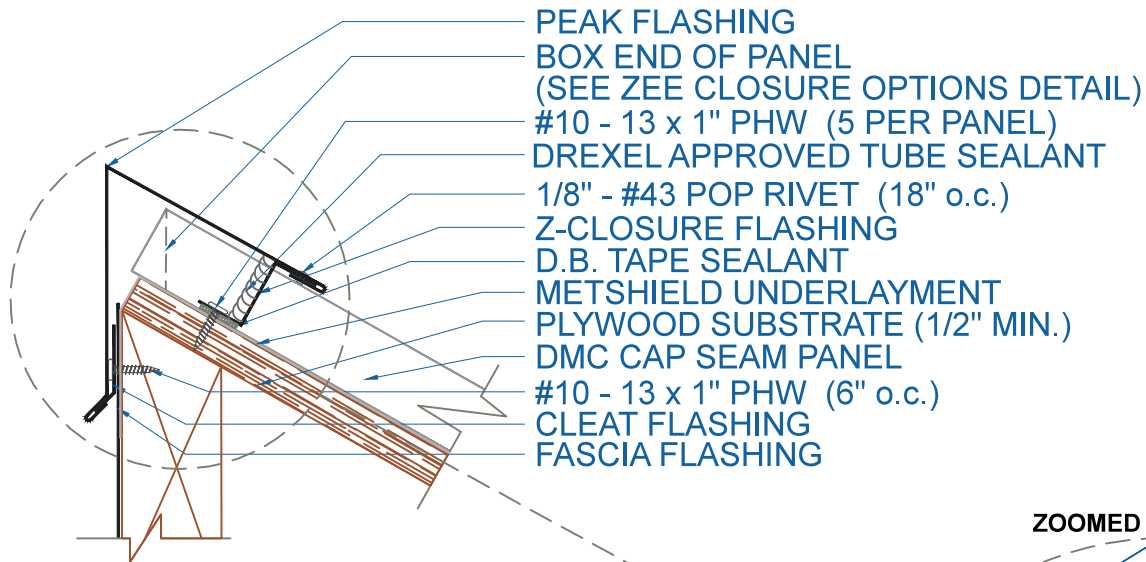

EFFECTIVE DATE: 08-14-2013
 SUBJECT TO CHANGE WITHOUT NOTICE

PEAK
 SCALE: 3" = 1'-0"

DrexelMetals
 Roofing Systems + Custom Fabrication



DMC CAP SEAM - PLYWOOD

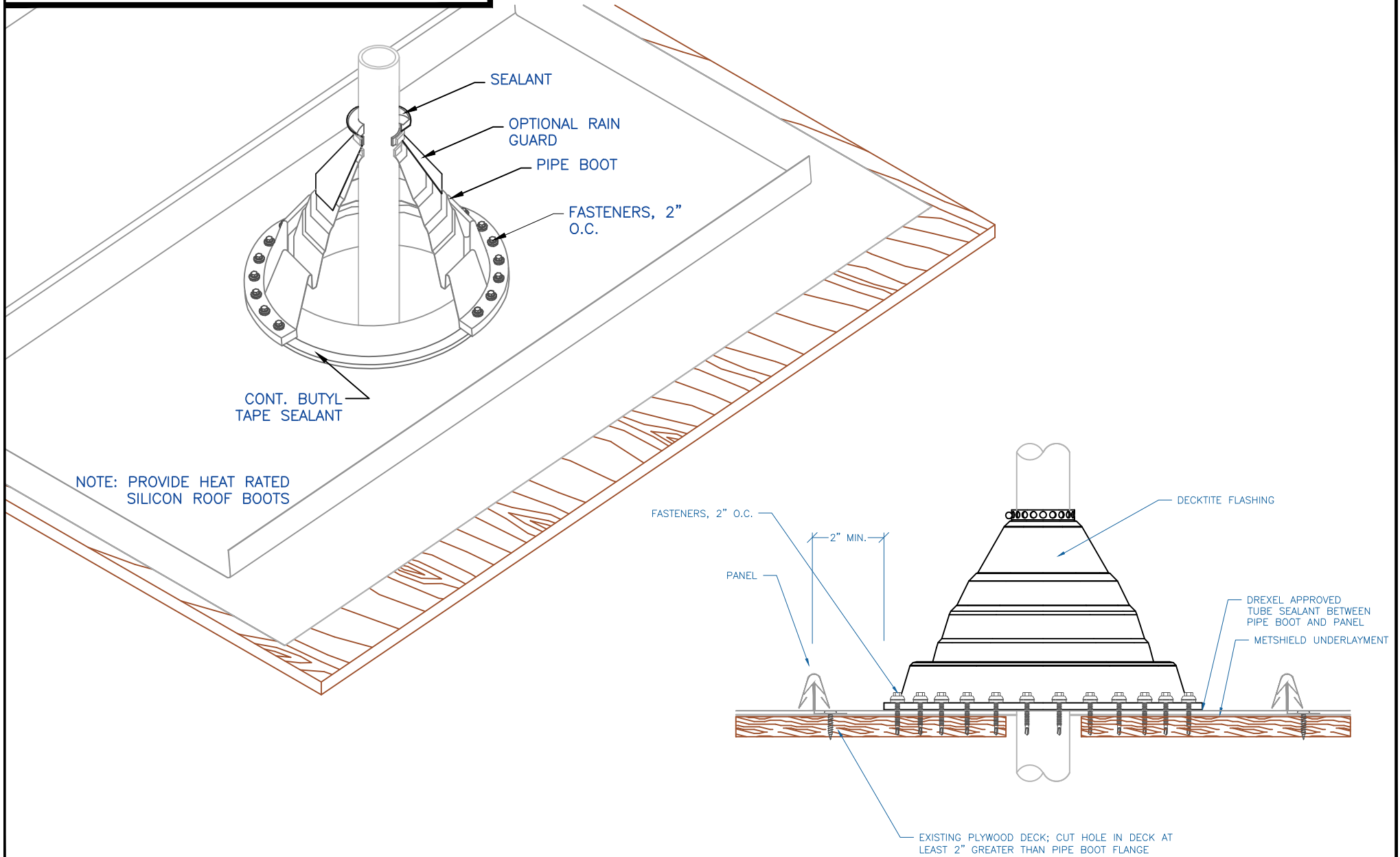

PIPE FLASHING DETAIL

SCALE: NTS

DMC CAP SEAM - PLYWOOD

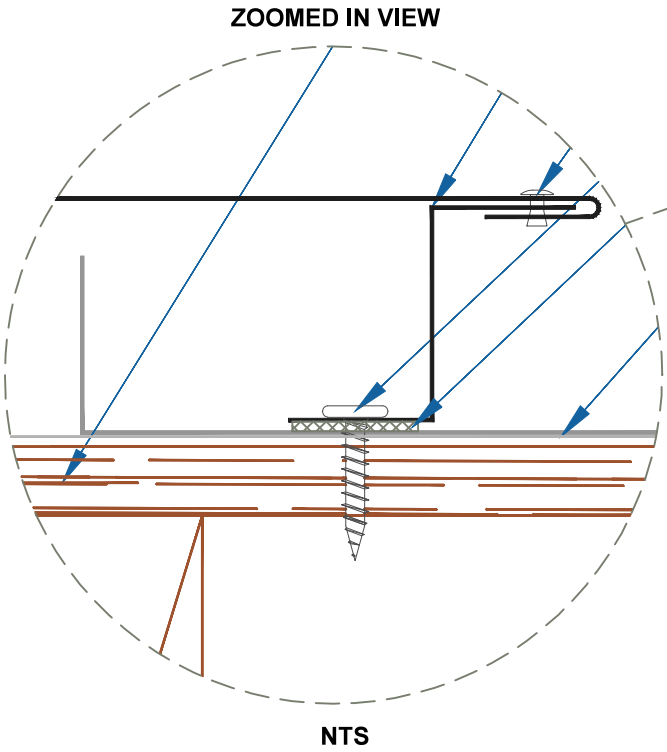
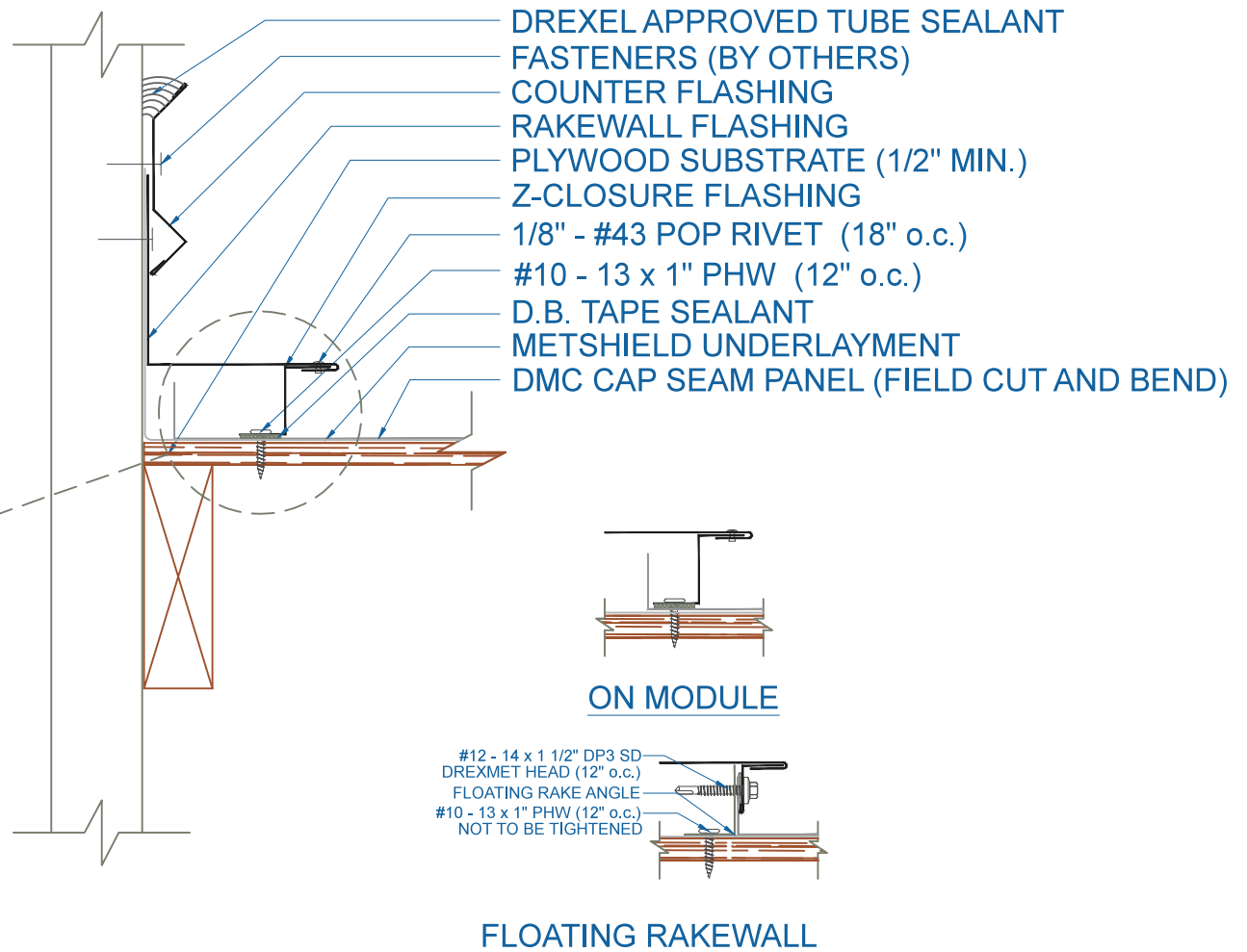

EFFECTIVE DATE: 08-14-2013
 SUBJECT TO CHANGE WITHOUT NOTICE

RAKEWALL
 SCALE: 3" = 1'-0"

DMC CAP SEAM - PLYWOOD

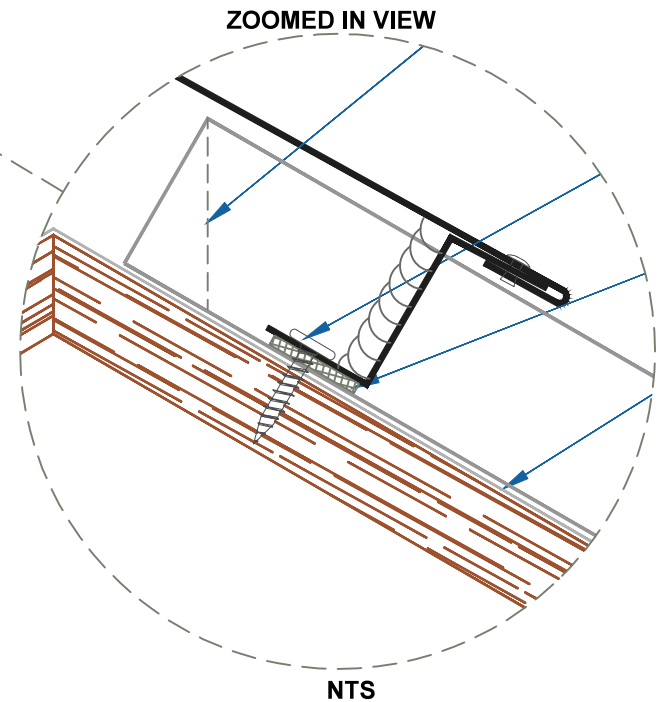
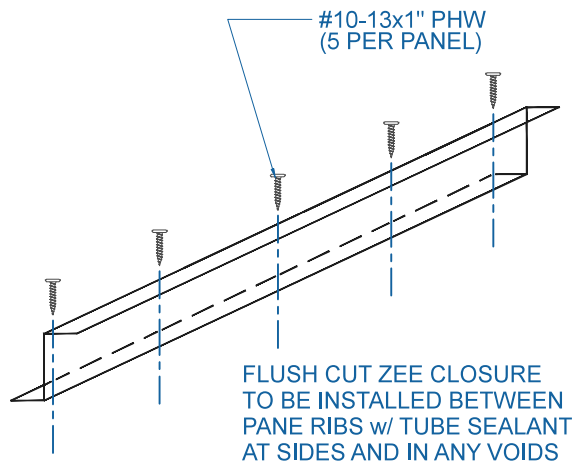
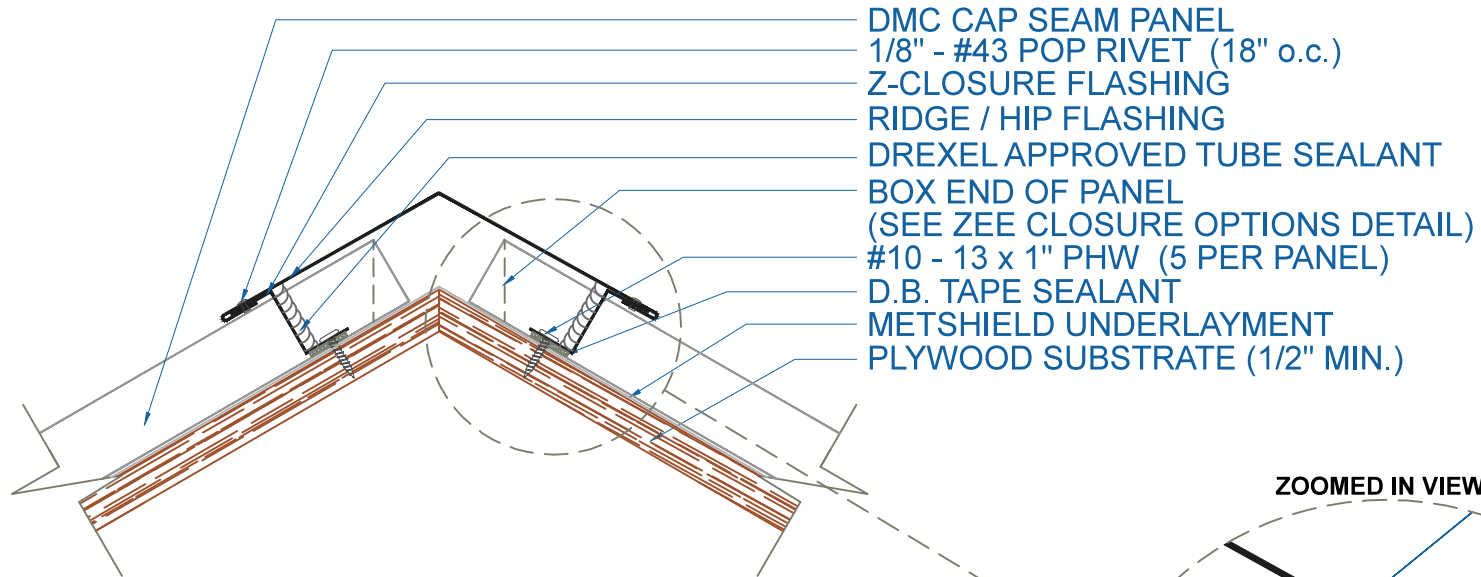

EFFECTIVE DATE: 08-14-2013
SUBJECT TO CHANGE WITHOUT NOTICE

RIDGE / HIP

SCALE: 3" = 1'-0"

DrexelMetals
Roofing Systems + Custom Fabrication



DMC CAP SEAM - PLYWOOD

- DMC CAP SEAM PANEL
- #10 - 13 x 1" PHW (12" o.c.)
- D.B. TAPE SEALANT
- OFFSET CLEAT FLASHING
- FIELD CUT & HEM PANEL 180°
- BOX END OF PANEL
(SEE ZEE CLOSURE OPTIONS DETAIL)
- TRANSITION FLASHING
- 1/8" - #43 POP RIVET (18" o.c.)
- Z-CLOSURE
- #10 - 13 x 1" PHW (5 PER PANEL)
- D.B. TAPE SEALANT
- PLYWOOD SUBSTRATE (1/2" MIN.)
- DMC CAP SEAM PANEL
- METSHIELD UNDERLAYMENT

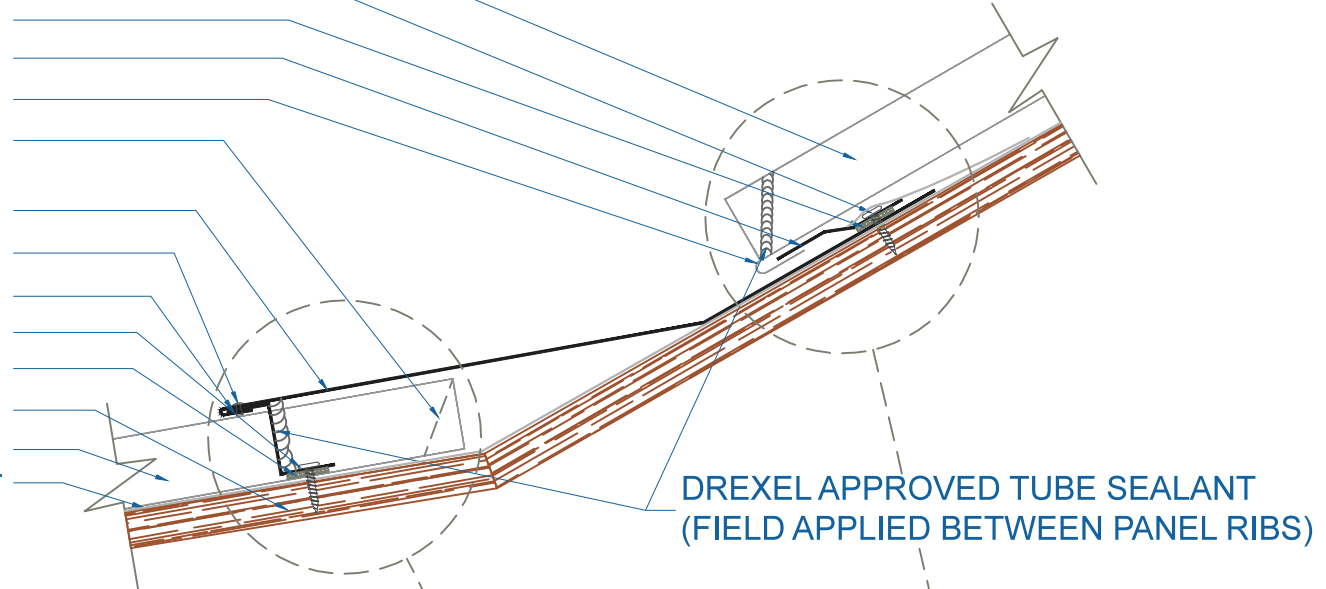

DREXEL APPROVED TUBE SEALANT
(FIELD APPLIED BETWEEN PANEL RIBS)

ZOOMED IN VIEW

ZOOMED IN VIEW

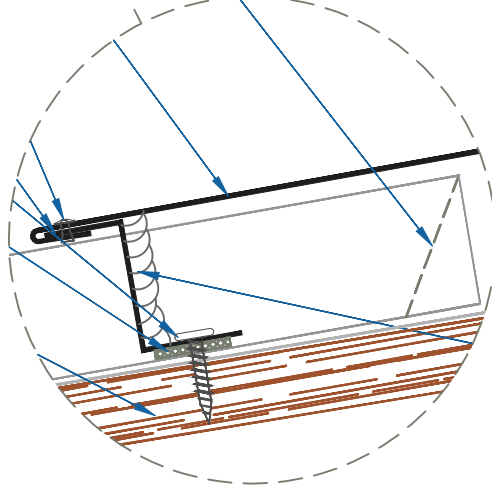
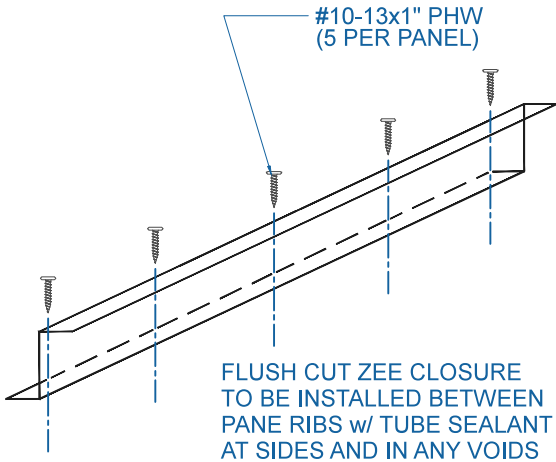

NTS

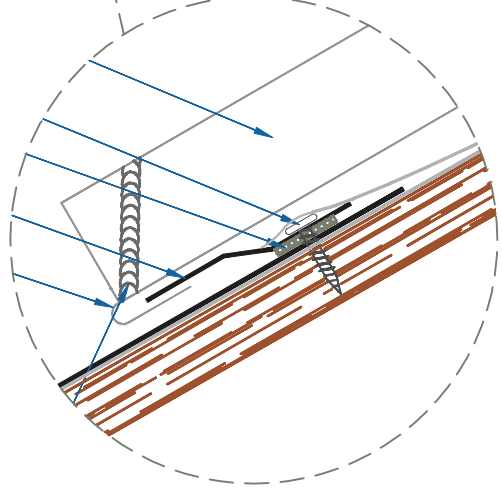

NTS

TRANSITION

SCALE: 3" = 1'-0"

EFFECTIVE DATE: 08-14-2013
SUBJECT TO CHANGE WITHOUT NOTICE



DMC CAP SEAM - PLYWOOD

ZOOMED IN VIEW

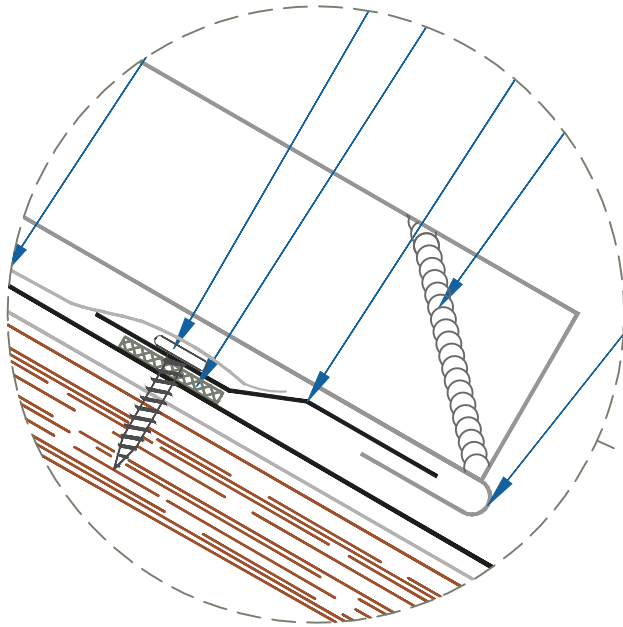

NTS

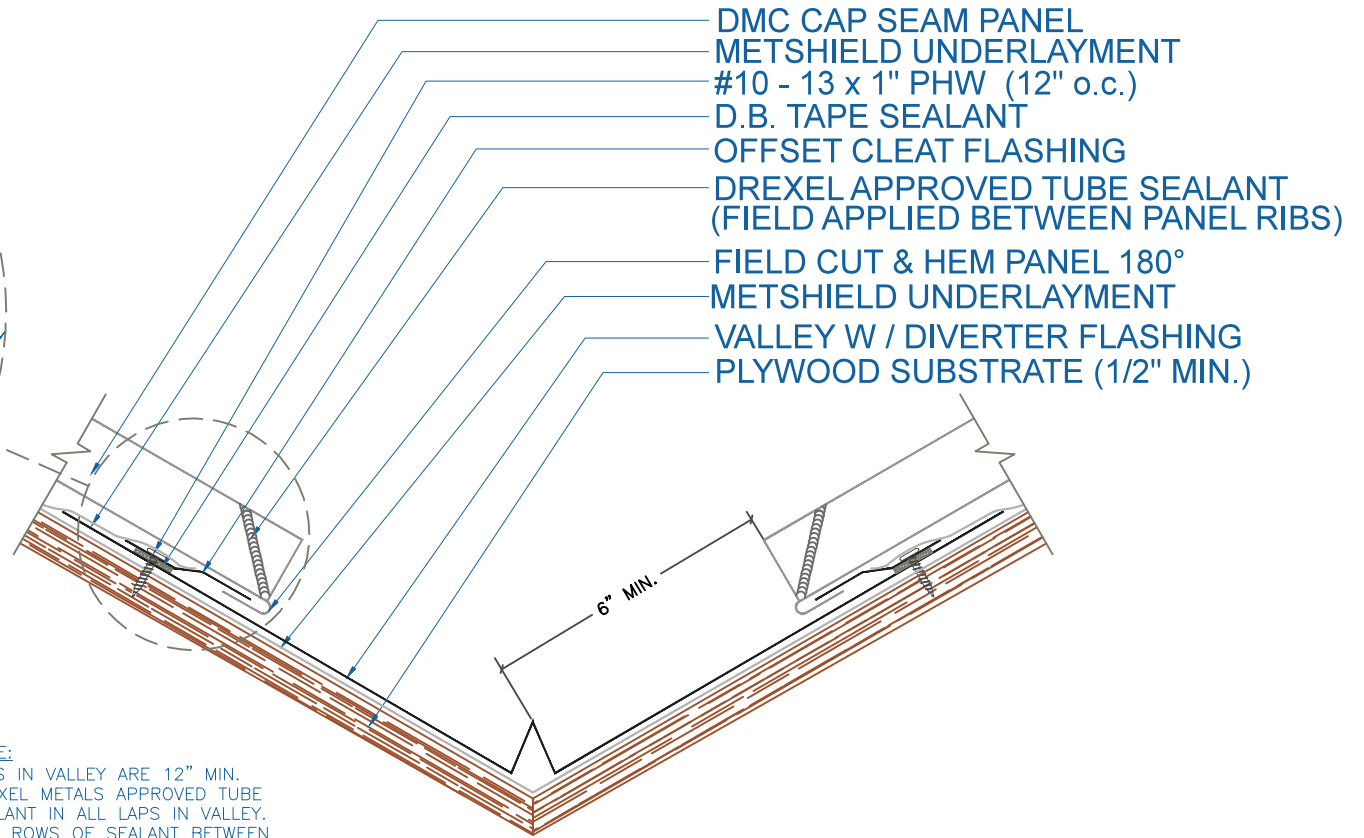

NOTE:

- 1.) LAPS IN VALLEY ARE 12" MIN.
DREXEL METALS APPROVED TUBE SEALANT IN ALL LAPS IN VALLEY.
TWO ROWS OF SEALANT BETWEEN VALLEY LAPS, 4" UP FROM LAP.
- 2.) LARGE ROOF AREAS MAY REQUIRE A LARGER GAP BETWEEN PANEL AND DIVERTER TO ALLOW FOR STORM WATER RUN OFF.

VALLEY w/ DIVERTER

SCALE: 3" = 1'-0"

EFFECTIVE DATE: 08-14-2013
SUBJECT TO CHANGE WITHOUT NOTICE

DrexelMetals
Roofing Systems + Custom Fabrication



DMC CAP SEAM - PLYWOOD

ZOOMED IN VIEW

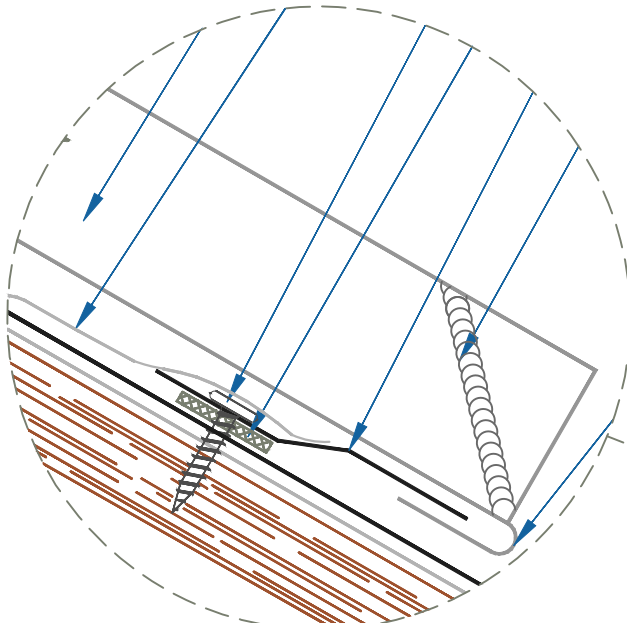

NTS

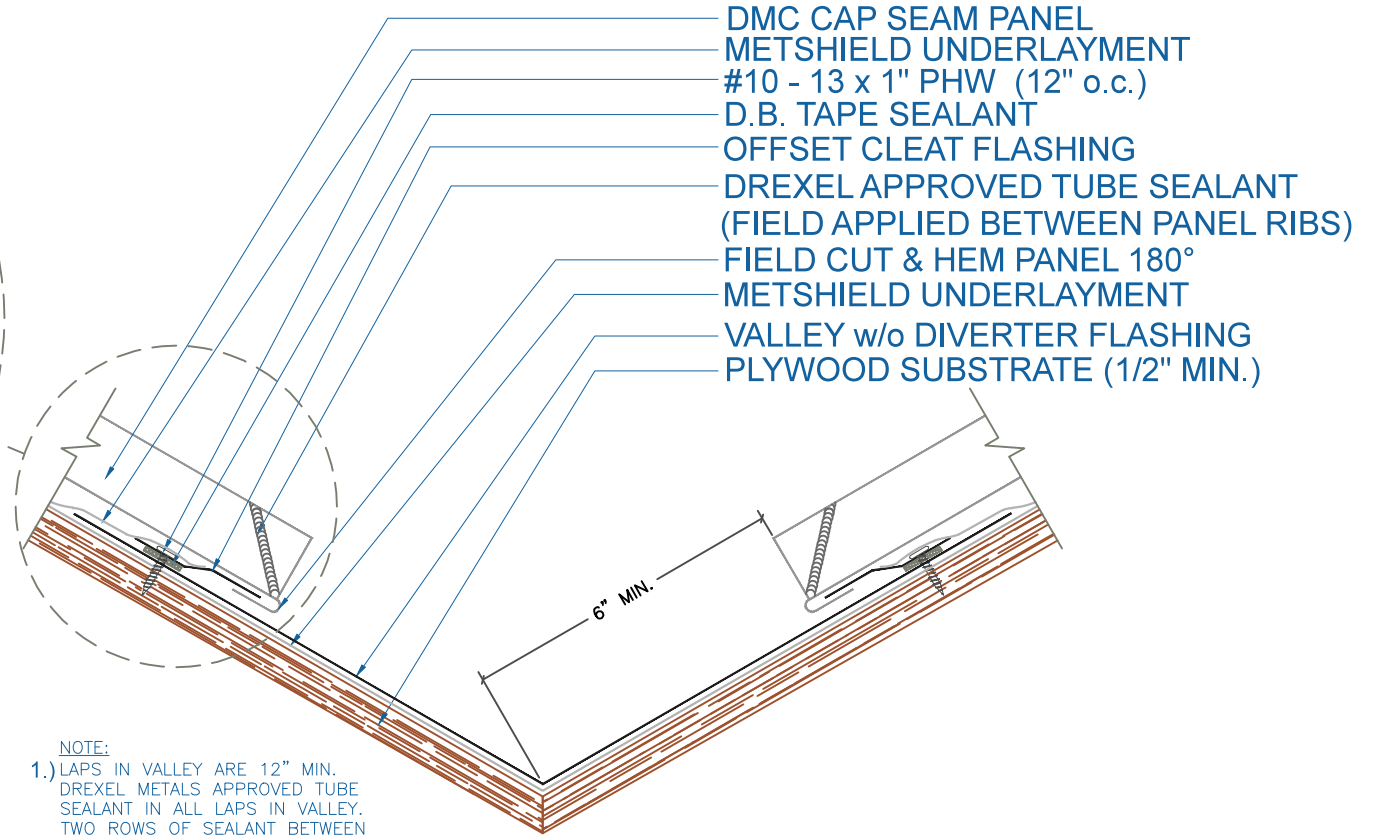

- DMC CAP SEAM PANEL
- METSHIELD UNDERLAYMENT
- #10 - 13 x 1" PHW (12" o.c.)
- D.B. TAPE SEALANT
- OFFSET CLEAT FLASHING
- DREXEL APPROVED TUBE SEALANT
(FIELD APPLIED BETWEEN PANEL RIBS)
- FIELD CUT & HEM PANEL 180°
- METSHIELD UNDERLAYMENT
- VALLEY w/o DIVERTER FLASHING
- PLYWOOD SUBSTRATE (1/2" MIN.)

NOTE:

- 1.) LAPS IN VALLEY ARE 12" MIN.
DREXEL METALS APPROVED TUBE SEALANT IN ALL LAPS IN VALLEY.
TWO ROWS OF SEALANT BETWEEN VALLEY LAPS, 4" UP FROM LAP.
- 2.) LARGE ROOF AREAS MAY REQUIRE A LARGER GAP BETWEEN PANEL AND DIVERTER TO ALLOW FOR STORM WATER RUN OFF.

VALLEY w/o DIVERTER



EFFECTIVE DATE: 08-14-2013
SUBJECT TO CHANGE WITHOUT NOTICE

SCALE: 3" = 1'-0"

DMC CAP SEAM - PLYWOOD

NOTE:

- 1.) LAPS IN VALLEYWALL ARE 12" MIN. DREXEL METALS APPROVED SEALANT IN ALL LAPS IN VALLEY. TWO ROWS OF SEALANT BETWEEN VALLEYWALL LAPS, 4" UP FROM LAP.
- 2.) LARGE ROOF AREAS MAY REQUIRE A LARGER GAP BETWEEN PANEL AND WALL TO ALLOW FOR STORM WATER RUN OFF.

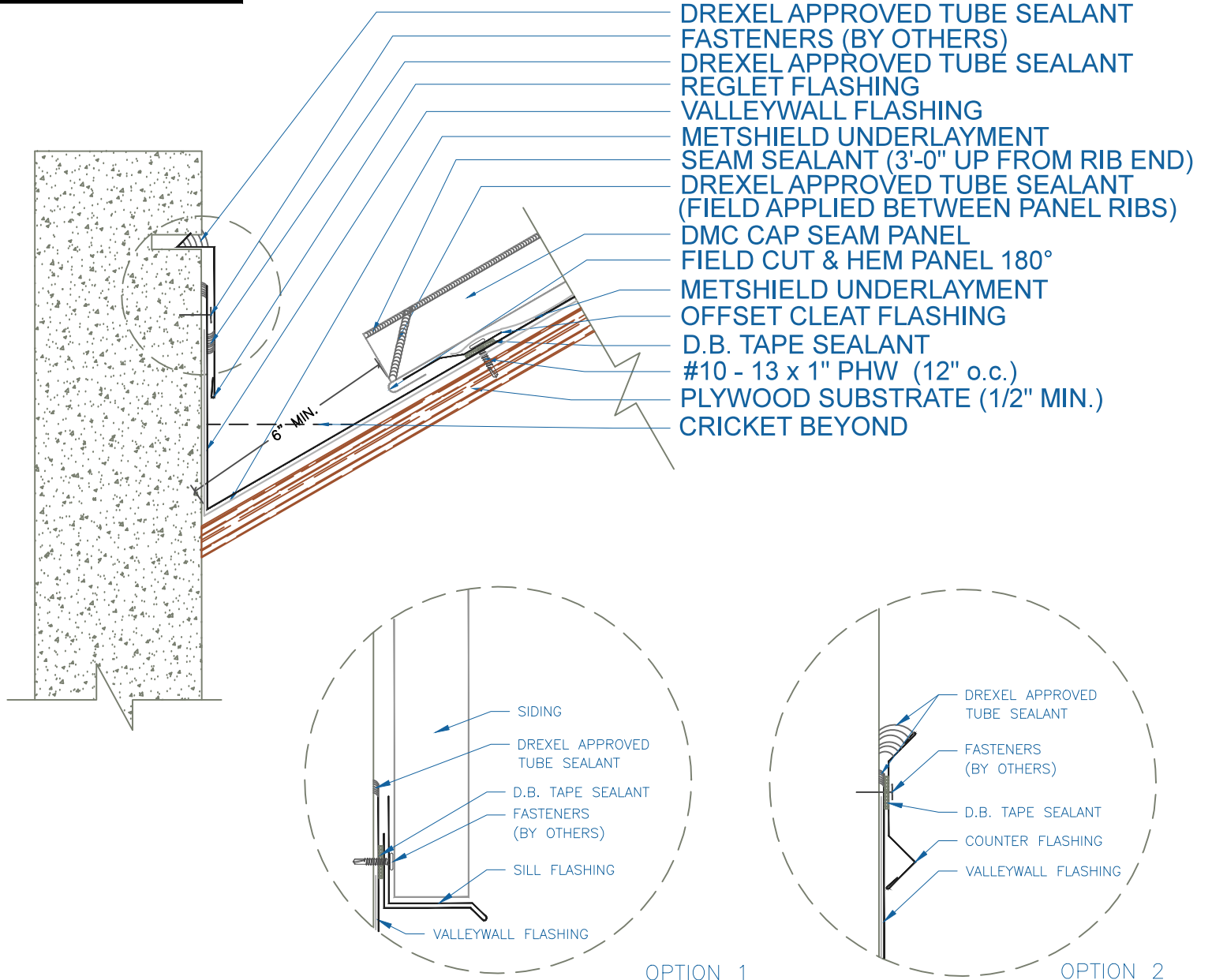

EFFECTIVE DATE: 08-14-2013
 SUBJECT TO CHANGE WITHOUT NOTICE

VALLEYWALL

SCALE: 3" = 1'-0"

Drexel Metals
 Roofing Systems + Custom Fabrication



DMC CAP SEAM - PLYWOOD

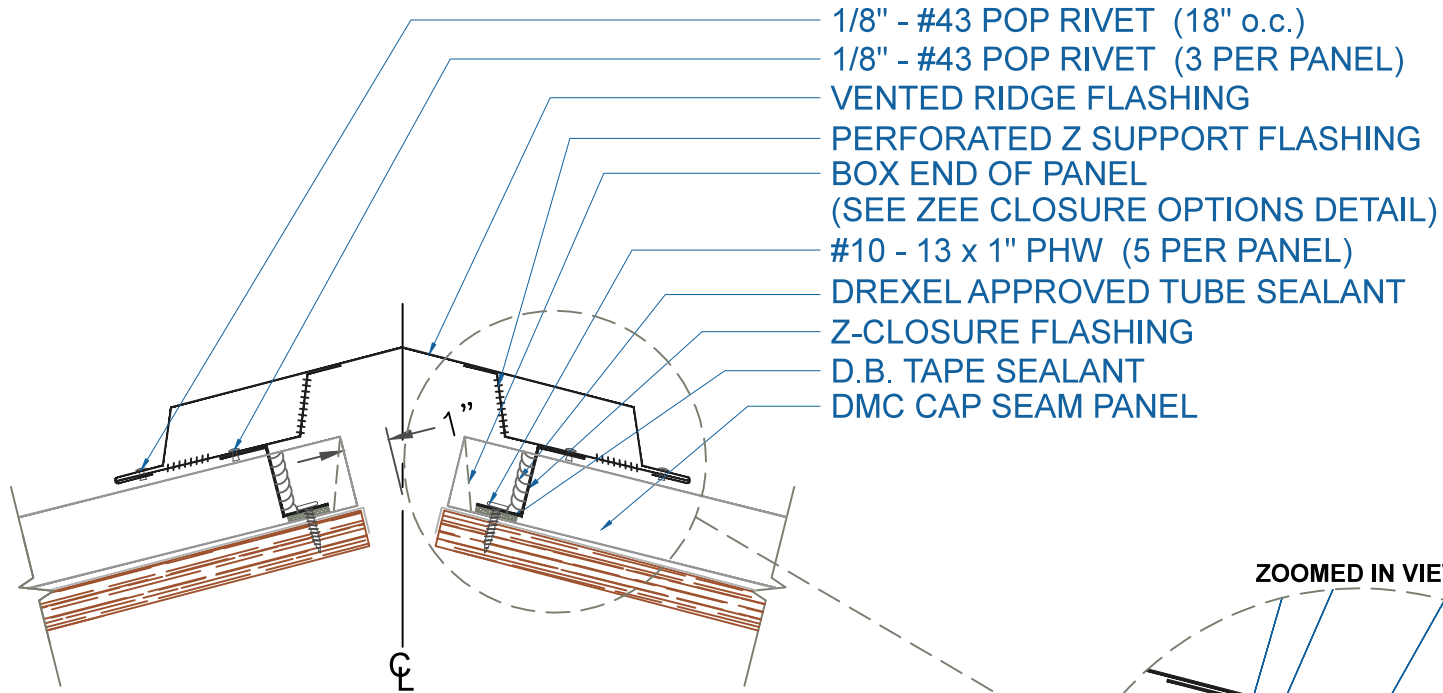

NOTE:
 1.) NET FREE AREA = 6.16 SQ IN/FT

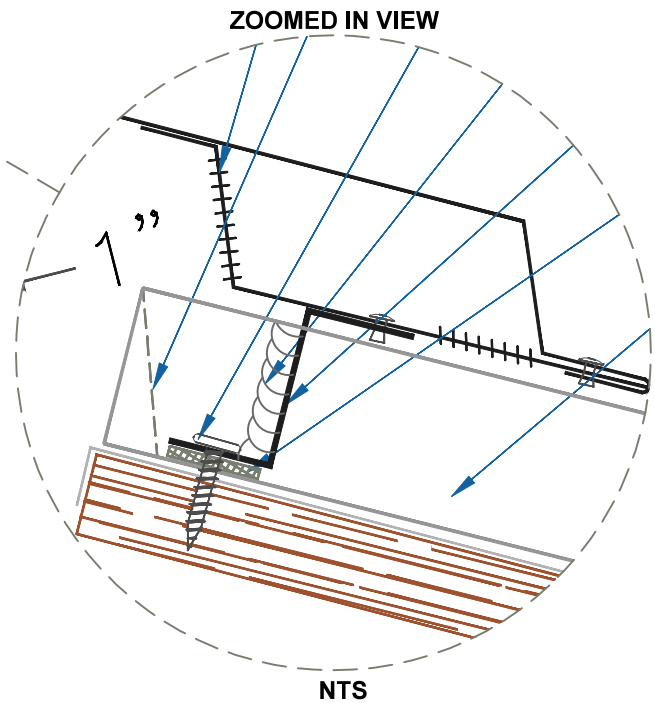
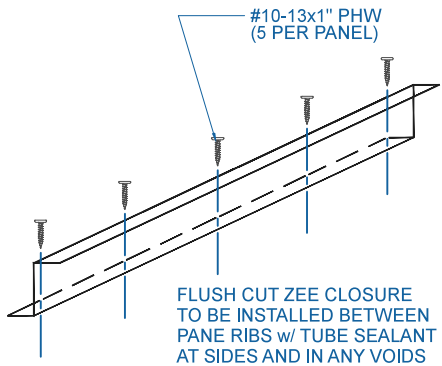

VENTED RIDGE / HIP

SCALE: 3" = 1'-0"

EFFECTIVE DATE: 08-14-2013
 SUBJECT TO CHANGE WITHOUT NOTICE