

Assembly Overview:

Econo Coping LT Installation Guide

This guide is provided to assist you in the installation process. Additional assistance is available by calling us at 888-321-9630. Thank you for choosing Drexel Metals.

<i>Contents:</i>	
Assembly Overview	1
Step 1: Installing 22ga Galv. Cleat	2
Step 2: Installing Miters	2
Step 3: Installing Straight Lengths	3
Step 4: Installing End Caps/Terms	3
Detail: Econo Coping LT	4

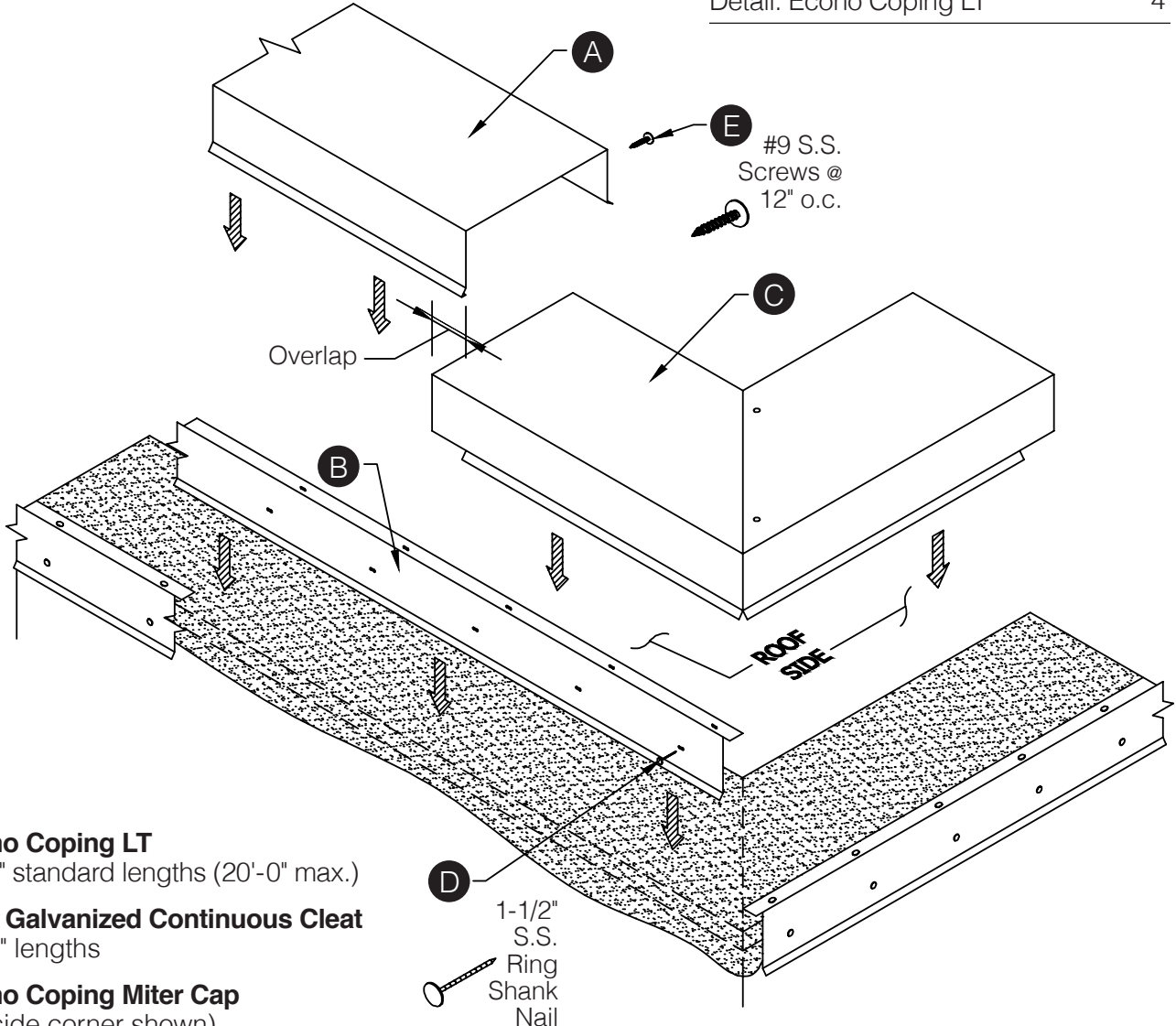

- A Econo Coping LT**
10'-0" standard lengths (20'-0" max.)
- B 22ga Galvanized Continuous Cleat**
10'-0" lengths
- C Econo Coping Miter Cap**
(Outside corner shown)
- D 1-1/4" S.S. Ring Shank Nail**
at 12" o.c. (6" o.c. within 3'-0" of corners)
(Included and required)
- E #9-13x1-1/2" S.S. Washered Screw**
at 12" o.c. (Included and required)

Step 1: Installing 22ga Galvanized Cleat

- Prior to installing the Cleat, ensure that all metal components have been isolated from ACQ treated lumber with appropriate membrane material.
- Butt Cleats together at corner conditions.
- Install Cleat working away from corners.
- Allow 1/8" gap between sections for thermal movement.
- Attach the Cleat using 1-1/4" S.S. Ring Shank Nails provided, into each pre-punched hole.
- When within 3'-0" of corners, attach Cleat with 1-1/4" S.S. Ring Shank Nails at 6" on center.

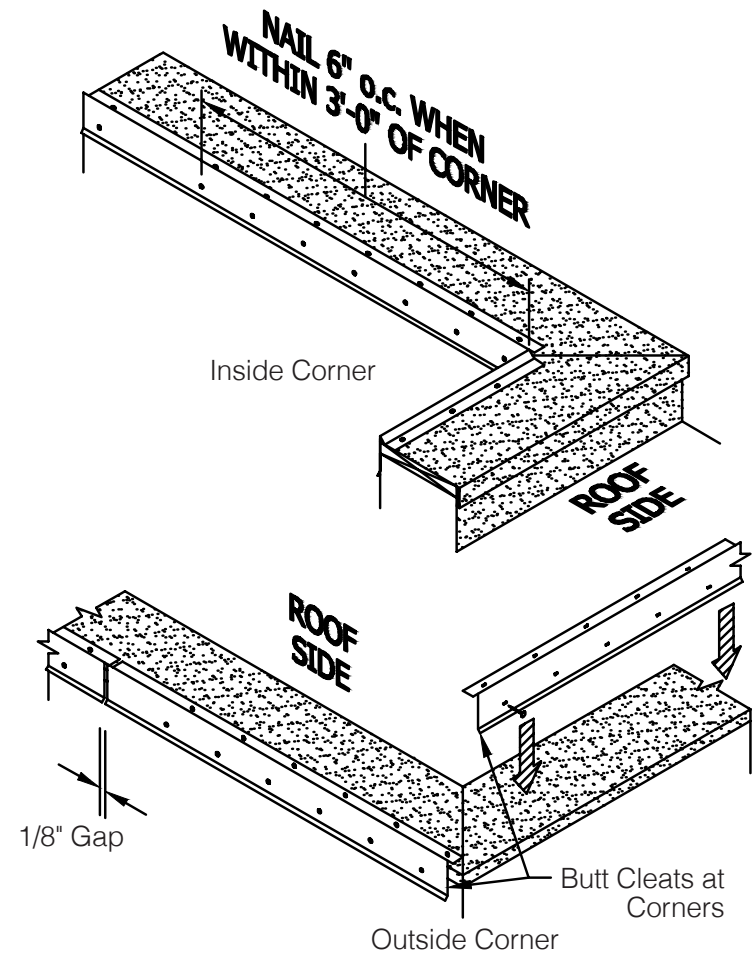

Step 2: Installing Econ Coping Miters

- Locate the Miter for the appropriate corner.
- Notch both sides of the Miter, as shown.
- Hook the drip of the Miter over the kickout of the face side of the Cleat, then rotate the Miter over the top of the parapet and screw the roof side leg of the Miter with #9-13x1-1/2" S.S. Washered Screws provided, at 12" on center.

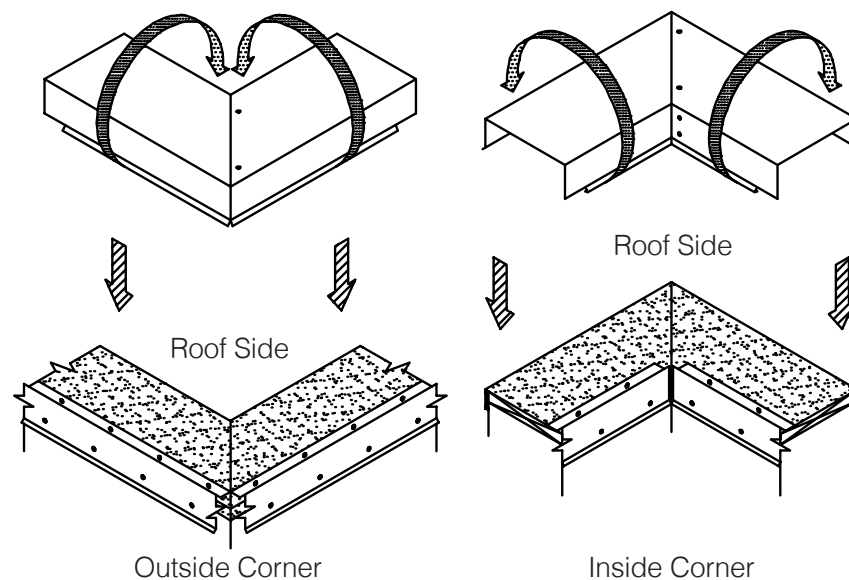

Step 3: Installing Econo Coping Straight Lengths

- Start by notching the end of the Coping opposite of the installed Miter.
- Install the Coping by hooking the drip over the kickout on the Cleat and rotating the Coping over the parapet wall and screw the roof side leg of the Coping with #9-13x1-1/2" S.S. Washered Screws provided at 12" on center.
- Consider lengths of all straight pieces prior to cutting to avoid creating relatively short sections adjacent to one another.

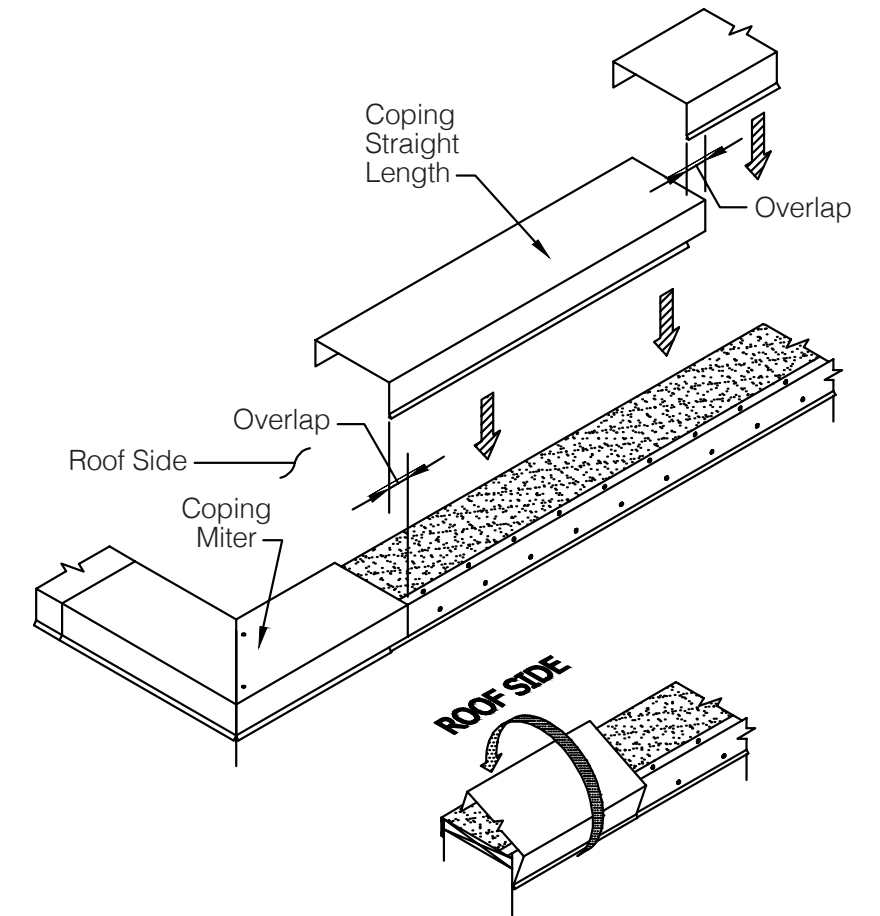

Step 4: Installing Econo Coping End Caps/Terms

- Pop-rivet the End Cap and End Term inserts into place.
- Install End Caps and End Terms by hooking the drip over the kickout on the Cleat and rotating over the part over the parapet.
- End Caps and End Terms must be restrained from moving by securing with a minimum of (2) #9-13x1-1/2" S.S. Washered Screws through the roof side leg.

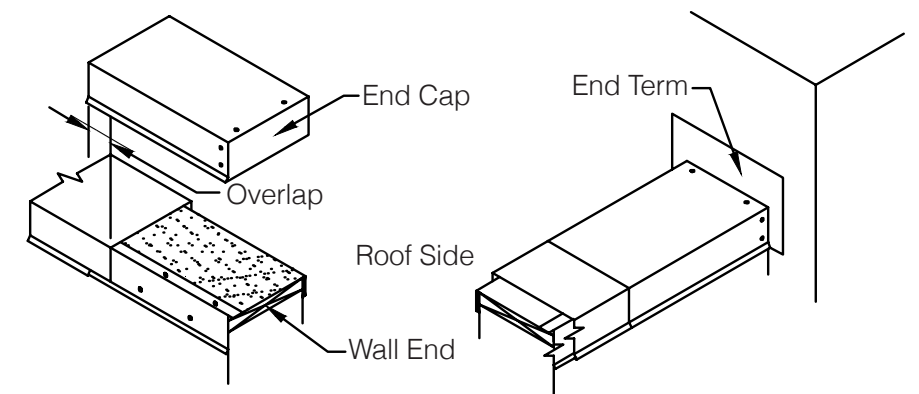

Typical Notch Procedure

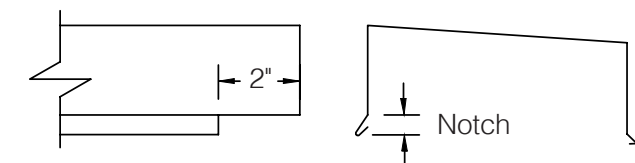

Econo Coping LT

Detail: Econo Coping LT - performance series

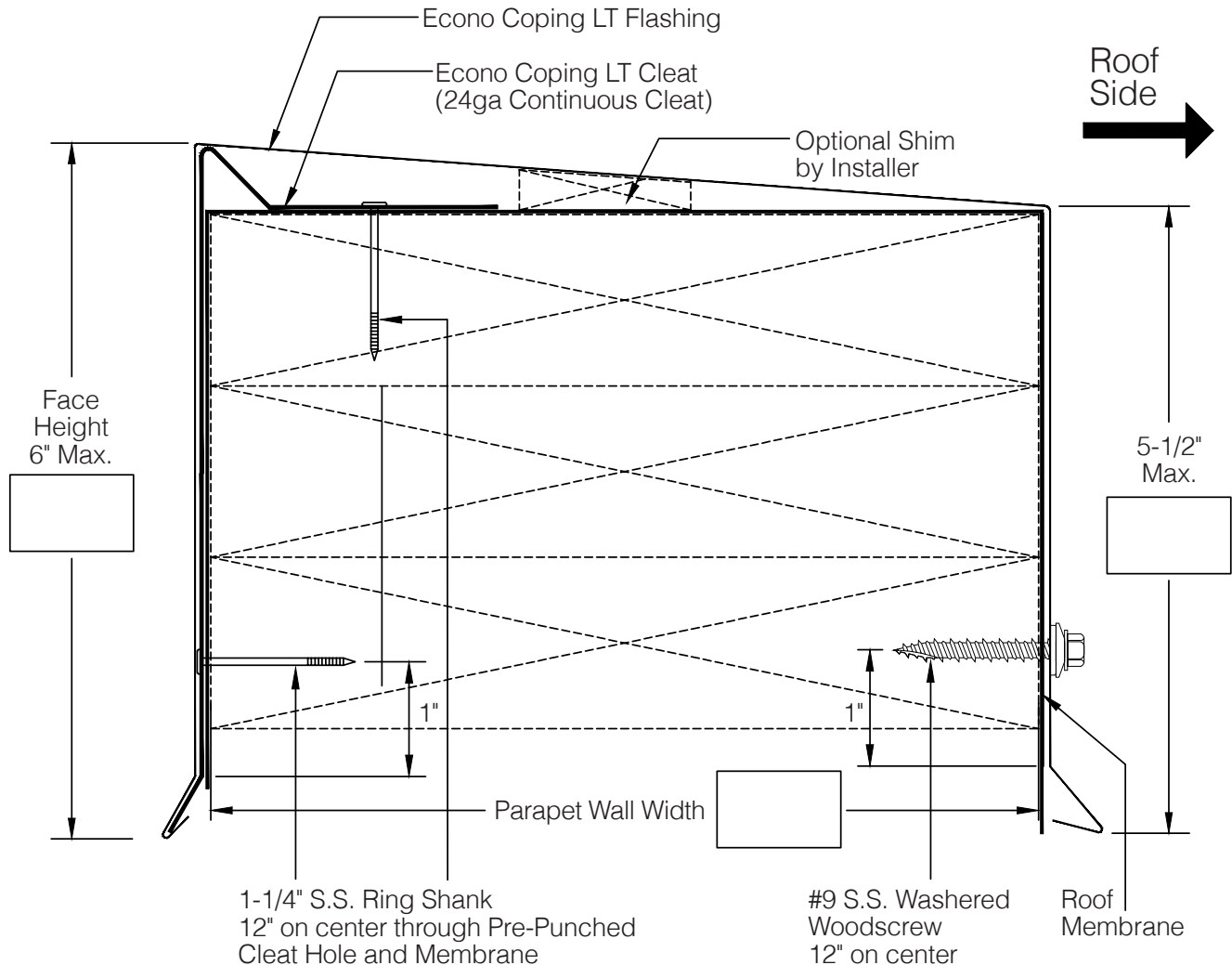

Notes:

1. Isolate all metal parts from ACQ treated wood or other galvanically incompatible material with appropriate membrane material.
2. Appliance attachments, such as lightning rods, signs, or antennae that penetrate the water seal, induce a galvanic reaction, or otherwise compromise the effectiveness of the roof edge system, shall be eliminated or isolated to prevent problems per section 8.0 if ANSI/SPRI ES-1. Appliances should also be isolated from, or not attached to, the roof edge system. Consult the lightning protection system manufacturer for specific attachment instructions.

