

DMC 200S - PLYWOOD

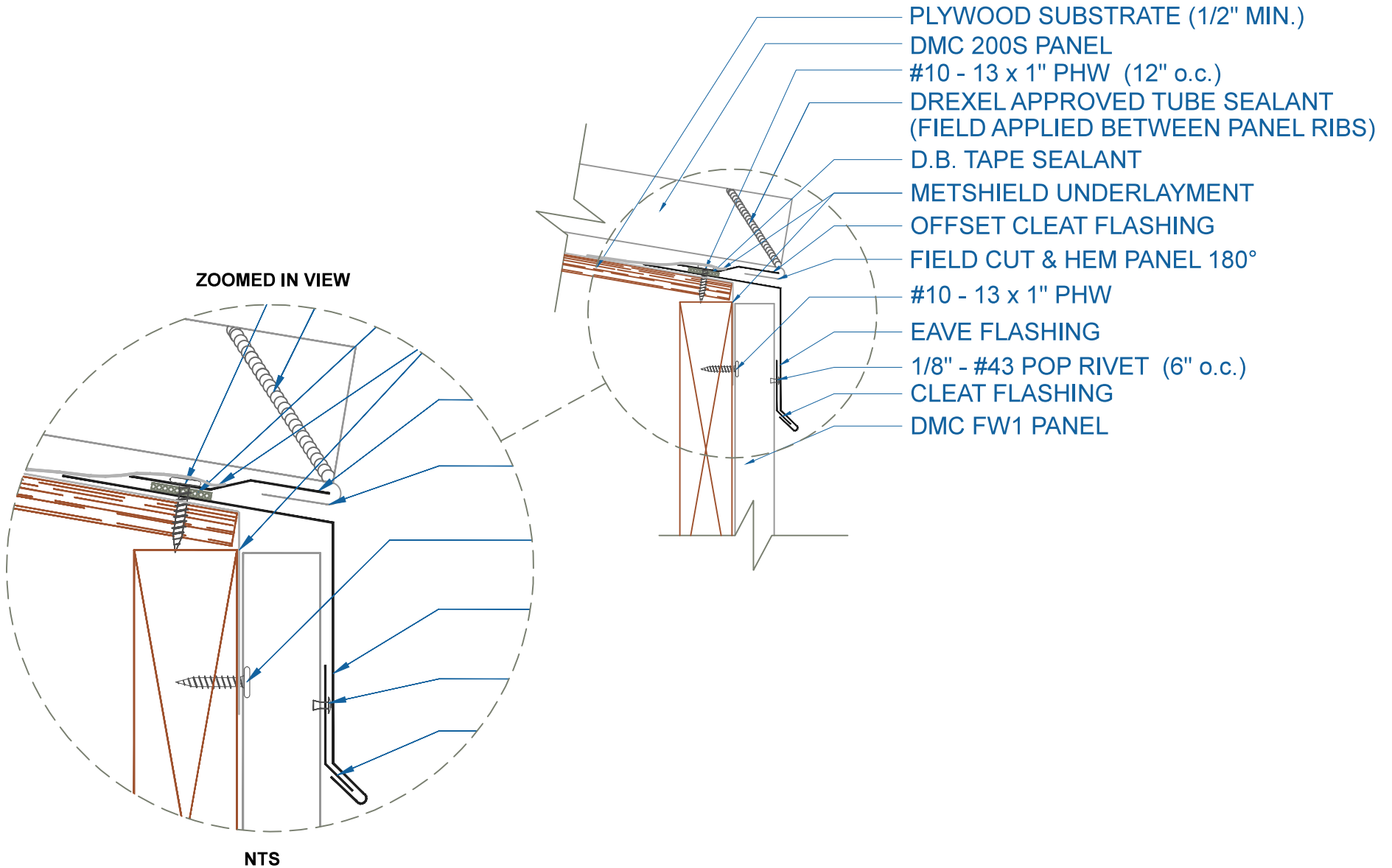

EAVE w/FLUSH PANEL

SCALE: 3" = 1'-0"